



COMMONWEALTH OF PENNSYLVANIA
DEPARTMENT OF ENVIRONMENTAL PROTECTION
AIR QUALITY PROGRAM

STATE ONLY SYNTHETIC MINOR OPERATING PERMIT

Issue Date: September 8, 2022 Effective Date: February 28, 2025
Revision Date: February 28, 2025 Expiration Date: September 7, 2027
Revision Type: Amendment

In accordance with the provisions of the Air Pollution Control Act, the Act of January 8, 1960, P.L. 2119, as amended, and 25 Pa. Code Chapter 127, the Owner, [and Operator if noted] (hereinafter referred to as permittee) identified below is authorized by the Department of Environmental Protection (Department) to operate the air emission source(s) more fully described in this permit. This Facility is subject to all terms and conditions specified in this permit. Nothing in this permit relieves the permittee from its obligations to comply with all applicable Federal, State and Local laws and regulations.

The regulatory or statutory authority for each permit condition is set forth in brackets. All terms and conditions in this permit are federally enforceable unless otherwise designated.

State Only Permit No: 08-00021

Synthetic Minor

Federal Tax Id - Plant Code: 38-3567931-1

Owner Information

Name: CABINETWORKS GROUP MICHIGAN LLC

Mailing Address: 217 LAMOKA RD
PO BOX 158
SAYRE, PA 18840

Plant Information

Plant: CABINETWORKS GROUP MICH LLC/ATHENS TWP PLT

Location: 08 Bradford County 08908 Athens Township

SIC Code: 2434 Manufacturing - Wood Kitchen Cabinets

Responsible Official

Name: HOLLY JENNINGS

Title: PLANT MGR

Phone: (570) 888 - 8457

Email: holly.jennings@cabinetworksgroup.com

Permit Contact Person

Name: ANDREW ROWE

Title: HSE MANAGER

Phone: (570) 888 - 8491

Email: andrew.rowe@cabinetworksgroup.com

[Signature] \_\_\_\_\_

MUHAMMAD Q. ZAMAN, ENVIRONMENTAL PROGRAM MANAGER, NORTHCENTRAL REGION



## SECTION A. Table of Contents

### Section A. Facility/Source Identification

Table of Contents  
Site Inventory List

### Section B. General State Only Requirements

- #001 Definitions.
- #002 Operating Permit Duration.
- #003 Permit Renewal.
- #004 Operating Permit Fees under Subchapter I.
- #005 Transfer of Operating Permits.
- #006 Inspection and Entry.
- #007 Compliance Requirements.
- #008 Need to Halt or Reduce Activity Not a Defense.
- #009 Duty to Provide Information.
- #010 Revising an Operating Permit for Cause.
- #011 Operating Permit Modifications
- #012 Severability Clause.
- #013 De Minimis Emission Increases.
- #014 Operational Flexibility.
- #015 Reactivation of Sources
- #016 Health Risk-based Emission Standards and Operating Practice Requirements.
- #017 Circumvention.
- #018 Reporting Requirements.
- #019 Sampling, Testing and Monitoring Procedures.
- #020 Recordkeeping.
- #021 Property Rights.
- #022 Alternative Operating Scenarios.
- #023 Reporting
- #024 Report Format

### Section C. Site Level State Only Requirements

- C-I: Restrictions
- C-II: Testing Requirements
- C-III: Monitoring Requirements
- C-IV: Recordkeeping Requirements
- C-V: Reporting Requirements
- C-VI: Work Practice Standards
- C-VII: Additional Requirements
- C-VIII: Compliance Certification
- C-IX: Compliance Schedule

### Section D. Source Level State Only Requirements

- D-I: Restrictions
- D-II: Testing Requirements
- D-III: Monitoring Requirements
- D-IV: Recordkeeping Requirements
- D-V: Reporting Requirements
- D-VI: Work Practice Standards
- D-VII: Additional Requirements

Note: These same sub-sections are repeated for each source!

### Section E. Source Group Restrictions

- E-I: Restrictions



## **SECTION A. Table of Contents**

- E-II: Testing Requirements
- E-III: Monitoring Requirements
- E-IV: Recordkeeping Requirements
- E-V: Reporting Requirements
- E-VI: Work Practice Standards
- E-VII: Additional Requirements

### **Section F. Alternative Operating Scenario(s)**

- F-I: Restrictions
- F-II: Testing Requirements
- F-III: Monitoring Requirements
- F-IV: Recordkeeping Requirements
- F-V: Reporting Requirements
- F-VI: Work Practice Standards
- F-VII: Additional Requirements

### **Section G. Emission Restriction Summary**

### **Section H. Miscellaneous**

**SECTION A. Site Inventory List**

Source ID	Source Name	Capacity/Throughput	Fuel/Material
031	BOILER 1	28.700	MMBTU/HR
032	BOILER 2	28.700	MMBTU/HR
P101	8 OAK KILNS		
P102	10 MAPLE KILNS		
P103	WOODWORKING SOURCES		
P104	WOOD WASTE STORAGE SILO		
P105	COMPONENT COATING, TOPCOAT, & CLEAN-UP		
P106	PREDRYER		
P107	STORAGE TANKS		
P108	PRESSROOM PRESSES		
P109	INTERNAL COMBUSTION SOURCES	N/A	Diesel Fuel
C01	ELECTROSTATIC PRECIPITATOR		
C031A	BOILER 1 PRIMARY MULTICLONE		
C031B	BOILER 1 SECONDARY MULTICLONE		
C032A	BOILER 2 PRIMARY MULTICLONE		
C032B	BOILER 2 SECONDARY MULTICLONE		
C103	WOODWORKING FABRIC COLLECTORS		
C104	WOOD WASTE SILO FABRIC COLLECTOR		
C105	REGENERATIVE THERMAL OXIDIZER		
FML01	NATURAL GAS LINE		
FML02	WOOD WASTE STORAGE SILO		
FML03	DIESEL FUEL		
S01	ELECTROSTATIC PRECIPITATOR STACK		
S103	WOODWORKING FABRIC COLLECTORS STACKS		
S104	WOOD WASTE SILO FABRIC COLLECTOR STACK		
S105	REGENERATIVE THERMAL OXIDIZER STACK		
S108A	PRESSROOM STACK A		
S108B	PRESSROOM STACK B		
S109	INTERNAL COMBUSTION SOURCES EXHAUSTS		
Z01	FUGITIVE EMISSIONS		

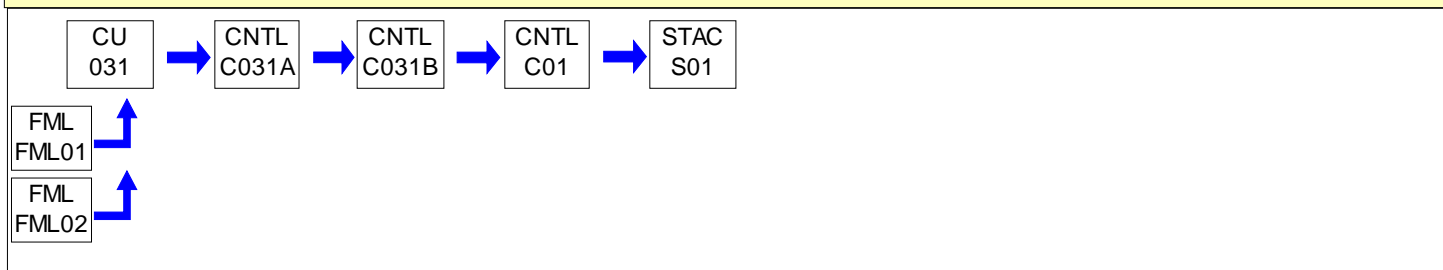
**PERMIT MAPS**



**PERMIT MAPS**

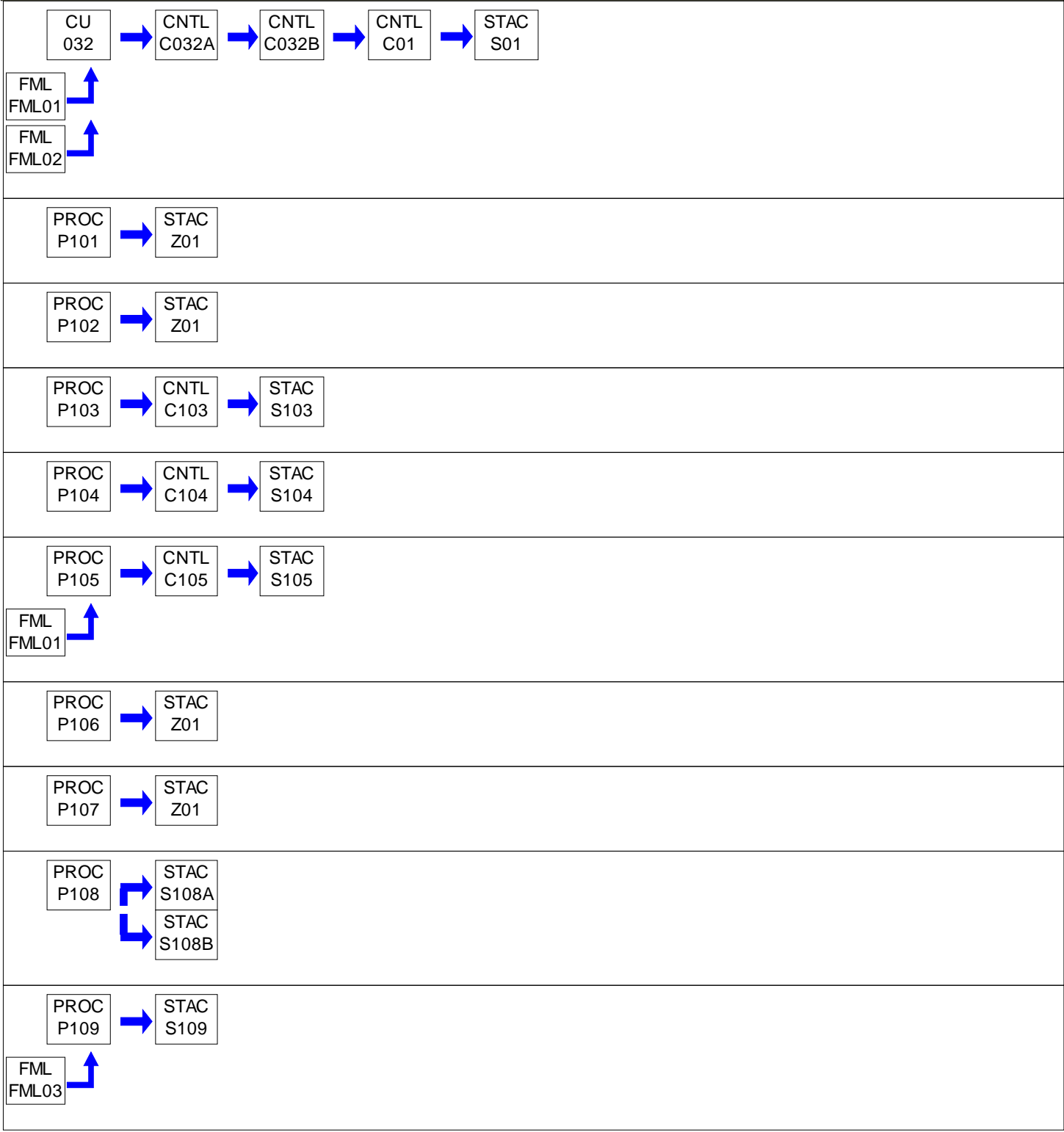

**SECTION B. General State Only Requirements****#001 [25 Pa. Code § 121.1]****Definitions.**

Words and terms that are not otherwise defined in this permit shall have the meanings set forth in Section 3 of the Air Pollution Control Act (35 P.S. § 4003) and in 25 Pa. Code § 121.1.

**#002 [25 Pa. Code § 127.446]****Operating Permit Duration.**

(a) This operating permit is issued for a fixed term of five (5) years and shall expire on the date specified on Page 1 of this permit.

(b) The terms and conditions of the expired permit shall automatically continue pending issuance of a new operating permit, provided the permittee has submitted a timely and complete application and paid applicable fees required under 25 Pa. Code Chapter 127, Subchapter I and the Department is unable, through no fault of the permittee, to issue or deny a new permit before the expiration of the previous permit.

**#003 [25 Pa. Code §§ 127.412, 127.413, 127.414, 127.446 & 127.703(b)]****Permit Renewal.**

(a) The permittee shall submit a timely and complete application for renewal of the operating permit to the appropriate Regional Air Program Manager. The application for renewal of the operating permit shall be submitted at least six (6) months and not more than 18 months before the expiration date of this permit.

(b) The application for permit renewal shall include the current permit number, a description of any permit revisions that occurred during the permit term, and any applicable requirements that were promulgated and not incorporated into the permit during the permit term. An application is complete if it contains sufficient information to begin processing the application, has the applicable sections completed and has been signed by a responsible official.

(c) The permittee shall submit with the renewal application a fee for the processing of the application as specified in 25 Pa. Code § 127.703(b). The fees shall be made payable to "The Commonwealth of Pennsylvania Clean Air Fund" and submitted with the fee form to the respective regional office.

(d) The renewal application shall also include submission of proof that the local municipality and county, in which the facility is located, have been notified in accordance with 25 Pa. Code § 127.413.

(e) The application for renewal of the operating permit shall also include submission of supplemental compliance review forms in accordance with the requirements of 25 Pa. Code § 127.412(b) and § 127.412(j).

(f) The permittee, upon becoming aware that any relevant facts were omitted or incorrect information was submitted in the permit application, shall promptly submit such supplementary facts or corrected information as necessary to address any requirements that become applicable to the source after the permittee submits a complete application, but prior to the date the Department takes action on the permit application.

**#004 [25 Pa. Code § 127.703]****Operating Permit Fees under Subchapter I.**

(a) The permittee shall pay the annual operating permit maintenance fee according to the following fee schedule in either paragraph (1) or (2) in accordance with 25 Pa. Code § 127.703(d) on or before December 31 of each year for the next calendar year.

(1) For a synthetic minor facility, a fee equal to:

(i) Four thousand dollars (\$4,000) for calendar years 2021—2025.

(ii) Five thousand dollars (\$5,000) for calendar years 2026—2030.

(iii) Six thousand three hundred dollars (\$6,300) for the calendar years beginning with 2031.

**SECTION B. General State Only Requirements**

(2) For a facility that is not a synthetic minor, a fee equal to:

- (i) Two thousand dollars (\$2,000) for calendar years 2021—2025.
- (ii) Two thousand five hundred dollars (\$2,500) for calendar years 2026—2030.
- (iii) Three thousand one hundred dollars (\$3,100) for the calendar years beginning with 2031.

(b) The applicable fees shall be made payable to "The Commonwealth of Pennsylvania Clean Air Fund" with the permit number clearly indicated and submitted to the respective regional office.

**#005 [25 Pa. Code §§ 127.450 (a)(4) and 127.464]****Transfer of Operating Permits.**

(a) This operating permit may not be transferred to another person, except in cases of transfer-of-ownership that are documented and approved by the Department.

(b) In accordance with 25 Pa. Code § 127.450(a)(4), a change in ownership of the source shall be treated as an administrative amendment if the Department determines that no other change in the permit is required and a written agreement has been submitted to the Department identifying the specific date of the transfer of permit responsibility, coverage and liability between the current and the new permittee and a compliance review form has been submitted to, and the permit transfer has been approved by, the Department.

(c) This operating permit is valid only for those specific sources and the specific source locations described in this permit.

**#006 [25 Pa. Code § 127.441 and 35 P.S. § 4008]****Inspection and Entry.**

(a) Upon presentation of credentials and other documents as may be required by law, the permittee shall allow the Department or authorized representatives of the Department to perform the following:

(1) Enter at reasonable times upon the permittee's premises where a source is located or emissions related activity is conducted, or where records are kept under the conditions of this permit;

(2) Have access to and copy, at reasonable times, any records that are kept under the conditions of this permit;

(3) Inspect at reasonable times, any facilities, equipment including monitoring and air pollution control equipment, practices, or operations regulated or required under this permit;

(4) Sample or monitor, at reasonable times, any substances or parameters, for the purpose of assuring compliance with the permit or applicable requirements as authorized by the Clean Air Act, the Air Pollution Control Act, or the regulations promulgated under the Acts.

(b) Pursuant to 35 P.S. § 4008, no person shall hinder, obstruct, prevent or interfere with the Department or its personnel in the performance of any duty authorized under the Air Pollution Control Act or regulations adopted thereunder including denying the Department access to a source at this facility. Refusal of entry or access may constitute grounds for permit revocation and assessment of criminal and/or civil penalties.

(c) Nothing in this permit condition shall limit the ability of the EPA to inspect or enter the premises of the permittee in accordance with Section 114 or other applicable provisions of the Clean Air Act.

**#007 [25 Pa. Code §§ 127.441 & 127.444]****Compliance Requirements.**

(a) The permittee shall comply with the conditions of this operating permit. Noncompliance with this permit constitutes a violation of the Clean Air Act and the Air Pollution Control Act and is grounds for one or more of the following:

**SECTION B. General State Only Requirements**

- (1) Enforcement action
- (2) Permit termination, revocation and reissuance or modification
- (3) Denial of a permit renewal application

(b) A person may not cause or permit the operation of a source which is subject to 25 Pa. Code Article III unless the source(s) and air cleaning devices identified in the application for the plan approval and operating permit and the plan approval issued for the source is operated and maintained in accordance with specifications in the applications and the conditions in the plan approval and operating permit issued by the Department. A person may not cause or permit the operation of an air contamination source subject to 25 Pa. Code Chapter 127 in a manner inconsistent with good operating practices.

(c) For purposes of Sub-condition (b) of this permit condition, the specifications in applications for plan approvals and operating permits are the physical configurations and engineering design details which the Department determines are essential for the permittee's compliance with the applicable requirements in this State-Only permit. Nothing in this sub-condition shall be construed to create an independent affirmative duty upon the permittee to obtain a predetermination from the Department for physical configuration or engineering design detail changes made by the permittee.

**#008 [25 Pa. Code § 127.441]****Need to Halt or Reduce Activity Not a Defense.**

It shall not be a defense for the permittee in an enforcement action that it was necessary to halt or reduce the permitted activity in order to maintain compliance with the conditions of this permit.

**#009 [25 Pa. Code §§ 127.442(a) & 127.461]****Duty to Provide Information.**

(a) The permittee shall submit reports to the Department containing information the Department may prescribe relative to the operation and maintenance of each source at the facility.

(b) The permittee shall furnish to the Department, in writing, information that the Department may request to determine whether cause exists for modifying, revoking and reissuing, or terminating this permit, or to determine compliance with the permit. Upon request, the permittee shall also furnish to the Department copies of records that the permittee is required to maintain in accordance with this permit.

**#010 [25 Pa. Code § 127.461]****Revising an Operating Permit for Cause.**

This operating permit may be terminated, modified, suspended or revoked and reissued if one or more of the following applies:

- (1) The permittee constructs or operates the source subject to the operating permit so that it is in violation of the Air Pollution Control Act, the Clean Air Act, the regulations thereunder, a plan approval, a permit or in a manner that causes air pollution.
- (2) The permittee fails to properly or adequately maintain or repair an air pollution control device or equipment attached to or otherwise made a part of the source.
- (3) The permittee has failed to submit a report required by the operating permit or an applicable regulation.
- (4) The EPA determines that the permit is not in compliance with the Clean Air Act or the regulations thereunder.

**#011 [25 Pa. Code §§ 127.450, 127.462, 127.465 & 127.703]****Operating Permit Modifications**

(a) The permittee is authorized to make administrative amendments, minor operating permit modifications and significant operating permit modifications, under this permit, as outlined below:



**SECTION B. General State Only Requirements**

(b) Administrative Amendments. The permittee shall submit the application for administrative operating permit amendments (as defined in 25 Pa. Code § 127.450(a)), according to procedures specified in § 127.450 unless precluded by the Clean Air Act or its regulations.

(c) Minor Operating Permit Modifications. The permittee shall submit the application for minor operating permit modifications (as defined 25 Pa. Code § 121.1) in accordance with 25 Pa. Code § 127.462.

(d) Significant Operating Permit Modifications. The permittee shall submit the application for significant operating permit modifications in accordance with 25 Pa. Code § 127.465.

(e) The applicable fees shall be made payable to "The Commonwealth of Pennsylvania Clean Air Fund" with the permit number clearly indicated and submitted to the respective regional office.

**#012 [25 Pa. Code § 127.441]****Severability Clause.**

The provisions of this permit are severable, and if any provision of this permit is determined by a court of competent jurisdiction to be invalid or unenforceable, such a determination will not affect the remaining provisions of this permit.

**#013 [25 Pa. Code § 127.449]****De Minimis Emission Increases.**

(a) This permit authorizes de minimis emission increases in accordance with 25 Pa. Code § 127.449 so long as the permittee provides the Department with seven (7) days prior written notice before commencing any de minimis emissions increase. The written notice shall:

(1) Identify and describe the pollutants that will be emitted as a result of the de minimis emissions increase.

(2) Provide emission rates expressed in tons per year and in terms necessary to establish compliance consistent with any applicable requirement.

(b) The Department may disapprove or condition de minimis emission increases at any time.

(c) Except as provided below in (d), the permittee is authorized to make de minimis emission increases (expressed in tons per year) up to the following amounts without the need for a plan approval or prior issuance of a permit modification:

(1) Four tons of carbon monoxide from a single source during the term of the permit and 20 tons of carbon monoxide at the facility during the term of the permit.

(2) One ton of NO<sub>x</sub> from a single source during the term of the permit and 5 tons of NO<sub>x</sub> at the facility during the term of the permit.

(3) One and six-tenths tons of the oxides of sulfur from a single source during the term of the permit and 8.0 tons of oxides of sulfur at the facility during the term of the permit.

(4) Six-tenths of a ton of PM<sub>10</sub> from a single source during the term of the permit and 3.0 tons of PM<sub>10</sub> at the facility during the term of the permit. This shall include emissions of a pollutant regulated under Section 112 of the Clean Air Act unless precluded by the Clean Air Act, the regulations thereunder or 25 Pa. Code Article III.

(5) One ton of VOCs from a single source during the term of the permit and 5.0 tons of VOCs at the facility during the term of the permit. This shall include emissions of a pollutant regulated under Section 112 of the Clean Air Act unless precluded by the Clean Air Act, the regulations thereunder or 25 Pa. Code Article III.

(6) Other sources and classes of sources determined to be of minor significance by the Department.

(d) In accordance with § 127.14, the permittee is authorized to install the following minor sources without the need for a plan approval or permit modification:

**SECTION B. General State Only Requirements**

- (1) Air conditioning or ventilation systems not designed to remove pollutants generated or released from other sources.
  - (2) Combustion units rated at 2,500,000 or less Btu per hour of heat input.
  - (3) Combustion units with a rated capacity of less than 10,000,000 Btu per hour heat input fueled by natural gas supplied by a public utility or by commercial fuel oils which are No. 2 or lighter, viscosity less than or equal to 5.82 c St, and which meet the sulfur content requirements of 25 Pa. Code §123.22 (relating to combustion units). For purposes of this permit, commercial fuel oil shall be virgin oil which has no reprocessed, recycled or waste material added.
  - (4) Space heaters which heat by direct heat transfer.
  - (5) Laboratory equipment used exclusively for chemical or physical analysis.
  - (6) Other sources and classes of sources determined to be of minor significance by the Department.
- (e) This permit does not authorize de minimis emission increases if the emissions increase would cause one or more of the following:
- (1) Increase the emissions of a pollutant regulated under Section 112 of the Clean Air Act except as authorized in Subparagraphs (c)(4) and (5) of this permit condition.
  - (2) Subject the facility to the prevention of significant deterioration requirements in 25 Pa. Code Chapter 127, Subchapter D and/or the new source review requirements in Subchapter E.
  - (3) Violate any applicable requirement of this permit, the Air Pollution Control Act, the Clean Air Act, or the regulations promulgated under either of the acts.
- (f) Emissions authorized under this permit condition shall be included in the monitoring, recordkeeping and reporting requirements of this permit.
- (g) Except for de minimis emission increases, installation of minor sources made pursuant to this permit condition and Plan Approval Exemptions under 25 Pa. Code § 127.14 (relating to exemptions), the permittee is prohibited from making changes or engaging in activities that are not specifically authorized under this permit without first applying for a plan approval. In accordance with § 127.14(b), a plan approval is not required for the construction, modification, reactivation, or installation of the sources creating the de minimis emissions increase.
- (h) The permittee may not meet de minimis emission threshold levels by offsetting emission increases or decreases at the same source.

**#014 [25 Pa. Code § 127.3]****Operational Flexibility.**

The permittee is authorized to make changes within the facility in accordance with the regulatory provisions outlined in 25 Pa. Code § 127.3 (relating to operational flexibility) to implement the operational flexibility requirements provisions authorized under Section 6.1(i) of the Air Pollution Control Act and the operational flexibility terms and conditions of this permit. The provisions in 25 Pa. Code Chapter 127 which implement the operational flexibility requirements include the following:

- (1) Section 127.14 (relating to exemptions)
- (2) Section 127.447 (relating to alternative operating scenarios)
- (3) Section 127.448 (relating to emissions trading at facilities with Federally enforceable emissions caps)
- (4) Section 127.449 (relating to de minimis emission increases)
- (5) Section 127.450 (relating to administrative operating permit amendments)

**SECTION B. General State Only Requirements**

(6) Section 127.462 (relating to minor operating permit modifications)

(7) Subchapter H (relating to general plan approvals and general operating permits)

**#015 [25 Pa. Code § 127.11a]****Reactivation of Sources**

(a) The permittee may not reactivate a source that has been out of operation or production for at least one year unless the reactivation is conducted in accordance with a plan approval granted by the Department or in accordance with reactivation and maintenance plans developed and approved by the Department in accordance with 25 Pa. Code § 127.11a(a).

(b) A source which has been out of operation or production for more than five (5) years but less than 10 years may be reactivated and will not be considered a new source if the permittee satisfies the conditions specified in 25 Pa. Code § 127.11a(b).

**#016 [25 Pa. Code § 127.36]****Health Risk-based Emission Standards and Operating Practice Requirements.**

(a) When needed to protect public health, welfare and the environment from emissions of hazardous air pollutants from new and existing sources, the permittee shall comply with the health risk-based emission standards or operating practice requirements imposed by the Department, except as precluded by §§ 6.6(d)(2) and (3) of the Air Pollution Control Act [35 P.S. § 4006.6(d)(2) and (3)].

(b) A person challenging a performance or emission standard established by the Department has the burden to demonstrate that performance or emission standard does not meet the requirements of Section 112 of the Clean Air Act.

**#017 [25 Pa. Code § 121.9]****Circumvention.**

No person may permit the use of a device, stack height which exceeds good engineering practice stack height, dispersion technique or other technique which, without resulting in reduction of the total amount of air contaminants emitted, conceals or dilutes an emission of air contaminants which would otherwise be in violation of 25 Pa. Code Article III, except that with prior approval of the Department, the device or technique may be used for control of malodors.

**#018 [25 Pa. Code §§ 127.402(d) & 127.442]****Reporting Requirements.**

(a) The permittee shall comply with the applicable reporting requirements of the Clean Air Act, the regulations thereunder, the Air Pollution Control Act and 25 Pa. Code Article III including Chapters 127, 135 and 139.

(b) The permittee shall submit reports to the Department containing information the Department may prescribe relative to the operation and maintenance of any air contamination source.

(c) Reports, test data, monitoring data, notifications and requests for renewal of the permit shall be submitted to the:

Regional Air Program Manager  
PA Department of Environmental Protection  
(At the address given in the permit transmittal letter, or otherwise notified)

(d) Any records or information including applications, forms, or reports submitted pursuant to this permit condition shall contain a certification by a responsible official as to truth, accuracy and completeness. The certifications submitted under this permit shall require a responsible official of the facility to certify that based on information and belief formed after reasonable inquiry, the statements and information in the documents are true, accurate and complete.

(e) Any records, reports or information submitted to the Department shall be available to the public except for such

**SECTION B. General State Only Requirements**

records, reports or information which meet the confidentiality requirements of § 4013.2 of the Air Pollution Control Act and §§ 112(d) and 114(c) of the Clean Air Act. The permittee may not request a claim of confidentiality for any emissions data generated for the facility.

**#019 [25 Pa. Code §§ 127.441(c) & 135.5]****Sampling, Testing and Monitoring Procedures.**

(a) The permittee shall comply with the monitoring, recordkeeping or reporting requirements of 25 Pa. Code Chapter 139 and the other applicable requirements of 25 Pa. Code Article III and additional requirements related to monitoring, reporting and recordkeeping required by the Clean Air Act and the regulations thereunder including the Compliance Assurance Monitoring requirements of 40 CFR Part 64, where applicable.

(b) Unless alternative methodology is required by the Clean Air Act and regulations adopted thereunder, sampling, testing and monitoring required by or used by the permittee to demonstrate compliance with any applicable regulation or permit condition shall be conducted in accordance with the requirements of 25 Pa. Code Chapter 139.

**#020 [25 Pa. Code §§ 127.441(c) and 135.5]****Recordkeeping.**

(a) The permittee shall maintain and make available, upon request by the Department, the following records of monitored information:

- (1) The date, place (as defined in the permit) and time of sampling or measurements.
- (2) The dates the analyses were performed.
- (3) The company or entity that performed the analyses.
- (4) The analytical techniques or methods used.
- (5) The results of the analyses.
- (6) The operating conditions as existing at the time of sampling or measurement.

(b) The permittee shall retain records of any required monitoring data and supporting information for at least five (5) years from the date of the monitoring, sample, measurement, report or application. Supporting information includes the calibration data and maintenance records and original strip-chart recordings for continuous monitoring instrumentation, and copies of reports required by the permit.

(c) The permittee shall maintain and make available to the Department upon request, records including computerized records that may be necessary to comply with the reporting, recordkeeping and emission statement requirements in 25 Pa. Code Chapter 135 (relating to reporting of sources). In accordance with 25 Pa. Code Chapter 135, § 135.5, such records may include records of production, fuel usage, maintenance of production or pollution control equipment or other information determined by the Department to be necessary for identification and quantification of potential and actual air contaminant emissions.

**#021 [25 Pa. Code § 127.441(a)]****Property Rights.**

This permit does not convey any property rights of any sort, or any exclusive privileges.

**#022 [25 Pa. Code § 127.447]****Alternative Operating Scenarios.**

The permittee is authorized to make changes at the facility to implement alternative operating scenarios identified in this permit in accordance with 25 Pa. Code § 127.447.

**SECTION B. General State Only Requirements****#023 [25 Pa. Code §135.3]****Reporting**

(a) If the facility is a Synthetic Minor Facility, the permittee shall submit by March 1 of each year an annual emissions report for the preceding calendar year. The report shall include information for all active previously reported sources, new sources which were first operated during the preceding calendar year, and sources modified during the same period which were not previously reported. All air emissions from the facility should be estimated and reported.

(b) A source owner or operator of a Synthetic Minor Facility may request an extension of time from the Department for the filing of an annual emissions report, and the Department may grant the extension for reasonable cause.

**#024 [25 Pa. Code §135.4]****Report Format**

If applicable, the emissions reports shall contain sufficient information to enable the Department to complete its emission inventory. Emissions reports shall be made by the source owner or operator in a format specified by the Department.

**SECTION C. Site Level Requirements****I. RESTRICTIONS.****Emission Restriction(s).****# 001 [25 Pa. Code §123.1]****Prohibition of certain fugitive emissions**

No person may permit the emission into the outdoor atmosphere of fugitive air contaminants from a source other than the following:

- (1) Construction or demolition of buildings or structures,
- (2) Grading, paving, and maintenance of roads and streets,
- (3) Use of roads and streets. Emissions from material in or on trucks, railroad cars, and other vehicular equipment are not considered as emissions from use of roads and streets,
- (4) Clearing of land,
- (5) Stockpiling of materials,
- (6) Open burning operations.
- (7) Sources and classes of sources other than those identified above, for which the permittee has obtained a determination from the Department that fugitive emissions from the source, after appropriate control, meet the following requirements:
  - (i) The emissions are of minor significance with respect to causing air pollution,
  - (ii) The emissions are not preventing or interfering with the attainment or maintenance of any ambient air quality standard.

**# 002 [25 Pa. Code §123.2]****Fugitive particulate matter**

No person may permit fugitive particulate matter to be emitted into the outdoor atmosphere from a source specified in Condition #001(1)-(7) above if the emissions are visible at the point the emissions pass outside the person's property.

**# 003 [25 Pa. Code §123.41]****Limitations**

No person may permit the emission into the outdoor atmosphere of visible air contaminants in such a manner that the opacity of the emission is either of the following:

- (1) Equal to or greater than 20% for a period or periods aggregating more than three minutes in any 1 hour,
- (2) Equal to or greater than 60% at any time.

**# 004 [25 Pa. Code §123.42]****Exceptions**

The emission limitations of 25 Pa. Code Section 123.41 shall not apply when:

- (1) The presence of uncombined water is the only reason for failure of the emission to meet the limitations,
- (2) The emission results from the operation of equipment used solely to train and test persons in observing the opacity of visible emissions,
- (3) The emission results from sources specified in 25 Pa. Code Section 123.1(a)(1)-(9).

**# 005 [25 Pa. Code §127.441]****Operating permit terms and conditions.**

No volatile organic compound-containing or hazardous air pollutant-containing glues or adhesives may be used in the cabinet door manufacturing process or any other manufacturing process in the respective facility other than glues and adhesives which have only a residual formaldehyde and/or VOC content. The combined emission of formaldehyde and VOCs resulting from the use of such glues and adhesives shall not, however, equal or exceed 1.5 tons in any 12

**SECTION C. Site Level Requirements**

consecutive month period.

The 1.5 ton limit is derived from a 1.0 ton limit established in Plan Approval 08-318-027 pursuant to 25 Pa. Code Sections 127.1 and 127.12 and an additional 0.5 ton limit approved via an August 9, 2017 RFD.

**# 006 [25 Pa. Code §127.441]****Operating permit terms and conditions.**

[Additional authority for this permit condition is derived from 25 Pa. Code Sections 127.1 and 127.12]

(a) The emission of sulfur oxides (SO<sub>x</sub>), expressed as SO<sub>2</sub>, from all sources at the facility shall not exceed 6.33 tons in any 12 consecutive month period.

(b) The emission of carbon monoxide (CO) from all sources at the facility shall not exceed 77.6 tons in any 12 consecutive month period.

(c) The emission of nitrogen oxides (NO<sub>x</sub>), expressed as NO<sub>2</sub>, from all sources at the facility shall not exceed 60.2 tons in any 12 consecutive month period.

(d) The emission of volatile organic compounds (VOCs) from all sources at the facility shall not exceed 32.9 tons in any 12 consecutive month period.

(e) The emission of each hazardous air pollutant (HAP) from all sources at the facility shall not equal or exceed 10 tons in any 12 consecutive month period.

(f) The emission of combined hazardous air pollutants (HAPs) from all sources at the facility shall not equal or exceed 25 tons in any 12 consecutive month period.

**# 007 [25 Pa. Code §127.441]****Operating permit terms and conditions.**

[Additional authority for this permit condition is derived from the permittee requesting the Synthetic Minor restriction]

[Compliance with the requirement specified in this streamlined permit condition assures compliance with the facility-wide particulate matter emission limitation, established pursuant to 25 Pa. Code Sections 127.1 and 127.12]

The emission of particulate matter, including particulate matter less than 10 microns (PM<sub>10</sub>), from all sources at the facility shall not equal or exceed 100 tons in any 12 consecutive month period.

**# 008 [25 Pa. Code §129.77.]****Control of emissions from the use or application of adhesives, sealants, primers and solvents.**

All adhesives, sealants, adhesive primers, sealant primers and related surface preparation solvents and cleaning solvents used at this facility shall comply with all VOC content limits specified in 25 Pa. Code Section 129.77 unless specifically exempted from this section pursuant to Sections 129.77(k), (l), (m) or (n).

**II. TESTING REQUIREMENTS.****# 009 [25 Pa. Code §127.441]****Operating permit terms and conditions.**

(a) Pursuant to 25 Pa. Code § 139.3, at least 90 calendar days prior to commencing a EPA reference method testing program, a test protocol shall be submitted to the Department for review and approval. Electronic copies shall be sent to the Northcentral Regional Office Air Quality Program Manager and the PSIMS Administrator in Central Office. The test protocol shall meet all applicable requirements specified in the most current version of the Department's Source Testing Manual.

(b) Pursuant to 25 Pa. Code § 139.3, at least 15 calendar days prior to commencing an emission testing program, notification as to the date and time of testing shall be given to the Northcentral Regional Office. Notification shall also be sent to the Division of Source Testing and Monitoring. Notification shall not be made without prior receipt of a protocol acceptance letter from the Department.

**SECTION C. Site Level Requirements**

(c) If applicable, pursuant to 40 CFR § 60.8(a), 40 CFR § 61.13(f) and 40 CFR § 63.7(g), complete test reports shall be submitted to the Department no later than 60 calendar days after completion of the on-site testing portion of an EPA reference method test program.

(d) Pursuant to 25 Pa. Code § 139.53(b) a complete test report shall include a summary of the emission results on the first page of the report indicating if each pollutant measured is within permitted limits and a statement of compliance or noncompliance with all applicable permit conditions. The summary results will include, at a minimum, the following information:

1. A statement that the owner or operator has reviewed the report from the emissions testing body and agrees with the findings.
2. Permit number(s) and condition(s) which are the basis for the evaluation.
3. Summary of results with respect to each applicable permit condition.
4. Statement of compliance or non-compliance with each applicable permit condition.

(e) Pursuant to 25 Pa. Code § 139.3, all submittals shall meet all applicable requirements specified in the most current version of the Department's Source Testing Manual.

(f) All testing shall be performed in accordance with the provisions of Chapter 139 of the Rules and Regulations of the Department of Environmental Protection.

(g) Pursuant to 25 Pa. Code §§ 139.53(a)(1) and 139.53(a)(3), electronic copies of all submittals, besides notifications, shall be sent to the Northcentral Regional Office Air Quality Program Manager, with deadlines verified. In addition, an electronic copy shall be sent to the PSIMS Administrator in Central Office. Email addresses are provided on the PA DEP website.

(h) The permittee shall insure all federal reporting requirements contained in the applicable subpart of 40 CFR are followed, including timelines more stringent than those contained herein. In the event of an inconsistency or any conflicting requirements between state and the federal, the most stringent provision, term, condition, method or rule shall be used by default.

**# 010 [25 Pa. Code §139.1]****Sampling facilities.**

Upon the request of the Department, the permittee shall provide adequate sampling ports, safe sampling platforms, and adequate utilities for the performance by the Department of tests on such source. The Department will set forth, in the request, the time period in which the facilities shall be provided as well as the specifications for such facilities.

**# 011 [25 Pa. Code §139.11]****General requirements.**

(a) As specified in 25 Pa. Code Section 139.11(1), performance tests shall be conducted while the source is operating at maximum routine operating conditions or under such other conditions, within the capacity of the equipment, as may be requested by the Department.

(b) As specified in 25 Pa. Code Section 139.11(2), the Department will consider test results for approval where sufficient information is provided to verify the source conditions existing at the time of the test and where adequate data is available to show the manner in which the test was conducted. Information submitted to the Department shall include, as a minimum, all of the following:

- (1) A thorough source description, including a description of any air cleaning devices and the flue,
- (2) Process conditions, for example, the charging rate of raw material or rate of production of final product, boiler pressure, oven temperature, and other conditions which may affect emissions from the process,
- (3) The location of sampling ports,
- (4) Effluent characteristics, including velocity, temperature, moisture content, gas density (percentage of CO, CO<sub>2</sub>, O<sub>2</sub> and N<sub>2</sub>), static and barometric pressures,
- (5) Sample collection techniques employed, including procedures used, equipment descriptions, and data to verify that isokinetic sampling for particulate matter collection occurred and that acceptable test conditions were met,



**SECTION C. Site Level Requirements**

(6) Laboratory procedures and results,

(7) Calculated results.

**III. MONITORING REQUIREMENTS.****# 012 [25 Pa. Code §123.43]****Measuring techniques**

Visible emissions may be measured using either of the following:

- (1) A device approved by the Department and maintained to provide accurate opacity measurements,
- (2) Observers, trained and qualified to measure plume opacity with the naked eye or with the aid of any devices approved by the Department.

**# 013 [25 Pa. Code §127.441]****Operating permit terms and conditions.**

(a) The permittee shall conduct a weekly inspection of the facility during daylight hours while the facility is operating to detect visible emissions, visible fugitive emissions, and malodors. Weekly inspections are necessary to determine:

- (1) The presence of visible emissions,
- (2) The presence of visible fugitive emissions,
- (3) The presence of malodors beyond the boundaries of the facility.

(b) All detected visible emissions, visible fugitive emissions, or malodors that have the potential to exceed applicable limits shall be reported to the manager of the facility.

**IV. RECORDKEEPING REQUIREMENTS.****# 014 [25 Pa. Code §127.441]****Operating permit terms and conditions.**

(a) The permittee shall keep records, on a monthly basis, of the amount of each individual hazardous air pollutant (HAP) emitted from each HAP-emitting source in the facility other than Source ID P105. These HAP records shall clearly show how each of these emission values was determined or derived. The specific method or methods by which these emission values are determined or derived is (are) subject to Department approval and the Department may, at any time, at its discretion, require alternate methods, including stack testing, to be employed for this purpose should it determine the need for such.

(b) These records shall be retained for a minimum of five (5) years and shall be made available to the Department upon request.

**# 015 [25 Pa. Code §127.441]****Operating permit terms and conditions.**

(a) The permittee shall maintain a logbook of the facility's weekly inspections performed. The logbook shall include the name of the company representative performing the inspection, the date and time of inspections, any instances of exceedances of visible emissions limitations, visible fugitive emissions limitations, and malodorous air emissions limitations, and the name of the manager informed if a potential exceedance is observed. The permittee shall also record any and all corrective action(s) taken to abate each recorded deviation to prevent future occurrences.

(b) These records shall be retained for a minimum of five (5) years and shall be made available to the Department upon request.

**# 016 [25 Pa. Code §127.441]****Operating permit terms and conditions.**

(a) The permittee shall keep records of the supporting calculations for CO, NO<sub>x</sub>, SO<sub>x</sub>, VOC, and particulate matter, including particulate matter less than 10 microns (PM<sub>10</sub>), emissions from all sources at the facility on a monthly basis and shall

**SECTION C. Site Level Requirements**

verify compliance with the CO, NO<sub>x</sub>, SO<sub>x</sub>, VOC, and particulate matter, including particulate matter less than 10 microns (PM<sub>10</sub>), emission limitations in any 12 consecutive month period.

(b) The permittee shall keep records of the supporting calculations for HAPs emissions from all sources at the facility on a monthly basis and shall verify compliance with the 'each HAP' emission limitation and the 'combined HAPs' emission limitation in any 12 consecutive month period.

(c) The permittee shall keep records of the supporting calculations for combined formaldehyde and VOCs emissions from glues and adhesives a monthly basis and shall verify compliance with the combined formaldehyde and VOCs emission limitation in any 12 consecutive month period.

(d) These records shall be retained for a minimum of five (5) years and shall be made available to the Department upon request.

**# 017 [25 Pa. Code §129.77.]****Control of emissions from the use or application of adhesives, sealants, primers and solvents.**

Pursuant to 25 Pa. Code Section 129.77(o) and (p), the permittee shall maintain records of all adhesives, sealants, adhesive primers, sealant primers and related surface preparation solvents and cleaning solvents used at this facility. These records shall be maintained for at least five years and made available to the Department upon request.

**# 018 [25 Pa. Code §135.5]****Recordkeeping**

(a) The permittee shall maintain and make available upon request by the Department records including computerized records that may be necessary to comply with 25 Pa. Code Section 135.3 (relating to reporting). These may include records of production, fuel usage, maintenance of production or pollution control equipment or other information determined by the Department to be necessary for identification and quantification of potential and actual air contaminant emissions.

(b) These records shall be retained for at least five years and shall be made available to the Department upon request.

**V. REPORTING REQUIREMENTS.****# 019 [25 Pa. Code §127.441]****Operating permit terms and conditions.**

(a) The permittee shall submit reports to the Department on a semi-annual basis that include the following:

(1) The supporting calculations used to verify compliance with the CO, NO<sub>x</sub>, SO<sub>x</sub>, VOC, and particulate matter, including particulate matter less than 10 microns (PM<sub>10</sub>), emission limitations for all sources at the facility in any 12 consecutive month period.

(2) The supporting calculations used to verify compliance with the 'each HAP' emission limitation and the 'combined HAPs' emission limitation for all sources at the facility in any 12 consecutive month period.

(3) The supporting calculations used to verify compliance with the combined formaldehyde and VOCs emission limitation for glues and adhesives in any 12 consecutive month period.

(b) The semi-annual reports shall be submitted to the Department no later than March 1 (for January 1 through December 31 of the previous year) and September 1 (for July 1 of the previous year through June 30 of the current year).

**# 020 [25 Pa. Code §127.441]****Operating permit terms and conditions.**

(a) The permittee shall submit reports to the Department on a semi-annual basis that include records of the amount of each individual hazardous air pollutant (HAP) emitted from each HAP-emitting source in the facility other than Source ID P105.

(b) The semi-annual reports shall be submitted to the Department by no later than March 1 (for January 1 through December 31 of the previous year) and September 1 (for July 1 of the previous year through June 30 of the current year).

**SECTION C. Site Level Requirements****# 021 [25 Pa. Code §127.441]****Operating permit terms and conditions.**

Upon request by the Department, the permittee shall submit all requested reports in accordance with the Department's suggested format.

**# 022 [25 Pa. Code §127.441]****Operating permit terms and conditions.**

The submission of all requests, reports, applications, submittals and other communications required by the Standards of Performance for New Stationary Sources (40 CFR Part 60) and/or the National Emissions Standards for Hazardous Air Pollutants (40 CFR Part 63) shall be submitted to both the U. S. Environmental Protection Agency and the Department. The Environmental Protection Agency copies may be sent to:

R3\_Air\_Apps\_and\_Notices@epa.gov

and

The Pennsylvania Department of Environmental Protection  
Air Quality Program Manager  
208 W. Third Street, Suite 101  
Williamsport, PA 17701-6448

**# 023 [25 Pa. Code §127.442]****Reporting requirements.**

- (a) The permittee shall report malfunctions, emergencies or incidents of excess emissions to the Department. A malfunction is any sudden, infrequent, and not reasonably preventable failure of air pollution control equipment, process equipment, or a process to operate in a normal or usual manner. An emergency is any situation arising from sudden and reasonably unforeseeable events beyond the control of the owner or operator of a facility which requires immediate corrective action to restore normal operation and which causes the emission source to exceed emissions, due to unavoidable increases in emissions attributable to the situation. An emergency shall not include situations caused by improperly designed equipment, lack of preventive maintenance, careless or improper operation, or operator error.
- (b) When the malfunction, emergency or incident of excess emissions poses an imminent danger to the public health, safety, welfare, or environment, it shall be reported to the Department and the County Emergency Management Agency by telephone within one (1) hour after the discovery of the malfunction, emergency or incident of excess emissions. The owner or operator shall submit a written or emailed report of instances of such malfunctions, emergencies or incidents of excess emissions to the Department within three (3) business days of the telephone report.
- (c) The report shall describe the following:

1. name, permit or authorization number, and location of the facility,
2. nature and cause of the malfunction, emergency or incident,
3. date and time when the malfunction, emergency or incident was first observed,
4. expected duration of excess emissions,
5. estimated rate of emissions,
6. corrective actions or preventative measures taken.

(d) Any malfunction, emergency or incident of excess emissions that is not subject to the notice requirements of paragraph (b) of this condition shall be reported to the Department by telephone within 24 hours (or by 4:00 PM of the next business day, whichever is later) of discovery and in writing or by e-mail within five (5) business days of discovery. The report shall contain the same information required by paragraph (c), and any permit specific malfunction reporting requirements.

(e) During an emergency an owner or operator may continue to operate the source at their discretion provided they submit justification for continued operation of a source during the emergency and follow all the notification and reporting requirements in accordance with paragraphs (b)-(d), as applicable, including any permit specific malfunction reporting requirements.

(f) Reports regarding malfunctions, emergencies or incidents of excess emissions shall be submitted to the appropriate DEP Regional Office Air Program Manager.

(g) Any emissions resulted from malfunction or emergency are to be reported in the annual emissions inventory report, if the annual emissions inventory report is required by permit or authorization.

**SECTION C. Site Level Requirements****# 024 [25 Pa. Code §135.3]****Reporting**

(a) A person who owns or operates a source to which 25 Pa. Code Chapter 135 applies, and who has previously been advised by the Department to submit a source report, shall submit by March 1 of each year an Annual Air Information Management Systems (AIMS) Emissions report for the preceding calendar year. The report shall include information for all previously reported sources, new sources which were first operated during the preceding calendar year, and sources modified during the same period which were not previously reported.

(b) A person who receives initial notification by the Department that an Annual Air Information Management Systems (AIMS) Emissions report is necessary, shall submit an initial Annual Air Information Management Systems (AIMS) Emissions report within sixty (60) days after receiving the notification or by March 1 of the year following the year for which the report is required, whichever is later.

(c) The permittee may request an extension of time from the Department for the filing of an Annual Air Information Management Systems (AIMS) Emissions report, and the Department may grant the extension for reasonable cause.

**# 025 [40 CFR Part 98 Mandatory Greenhouse Gas Reporting §40 CFR 98.1]****Subpart A - General Provision****Purpose and scope.**

This facility is subject to the mandatory greenhouse gas reporting requirements of 40 CFR 98.

**VI. WORK PRACTICE REQUIREMENTS.****# 026 [25 Pa. Code §123.1]****Prohibition of certain fugitive emissions**

For any source specified in 25 Pa. Code Section 123.1 subsection(s) (a)(1)-(7) or (a)(9), the permittee shall take all reasonable actions to prevent particulate matter from becoming airborne. These actions shall include, but not be limited to, the following:

(1) Use, where possible, of water or chemicals for control of dust in the demolition of buildings or structures, construction operations, the grading of roads, or the clearing of land,

(2) Application of asphalt, oil, or suitable chemicals on dirt roads, material stockpiles, and other surfaces which may give rise to airborne dusts,

(3) Paving and maintenance of roadways,

(4) Prompt removal of earth or other material from paved streets onto which earth or other material has been transported by trucking or earth moving equipment, erosion by water, or other means.

**VII. ADDITIONAL REQUIREMENTS.****# 027 [25 Pa. Code §121.7]****Prohibition of air pollution.**

No person may permit air pollution as that term is defined in the act [The Air Pollution Control Act (35 P.S. §§ 4001-4015)].

**# 028 [25 Pa. Code §123.31]****Limitations**

No person may permit the emission into the outdoor atmosphere of any malodorous air contaminants from any source in a manner that the malodors are detectable outside the property of the person on whose land the source is being operated.

**# 029 [25 Pa. Code §129.14]****Open burning operations**

No person may permit the open burning of material at this facility unless in accordance with 25 Pa. Code Section 129.14.

**# 030 [25 Pa. Code §129.77.]****Control of emissions from the use or application of adhesives, sealants, primers and solvents.**

All adhesives, sealants, adhesive primers, sealant primers and related surface preparation solvents and cleaning solvents

**SECTION C. Site Level Requirements**

used at this facility are subject to 25 Pa. Code Section 129.77.

**VIII. COMPLIANCE CERTIFICATION.**

No additional compliance certifications exist except as provided in other sections of this permit including Section B (relating to State Only General Requirements).

**IX. COMPLIANCE SCHEDULE.**

No compliance milestones exist.

**SECTION D. Source Level Requirements**

Source ID: 031

Source Name: BOILER 1

Source Capacity/Throughput: 28.700 MMBTU/HR

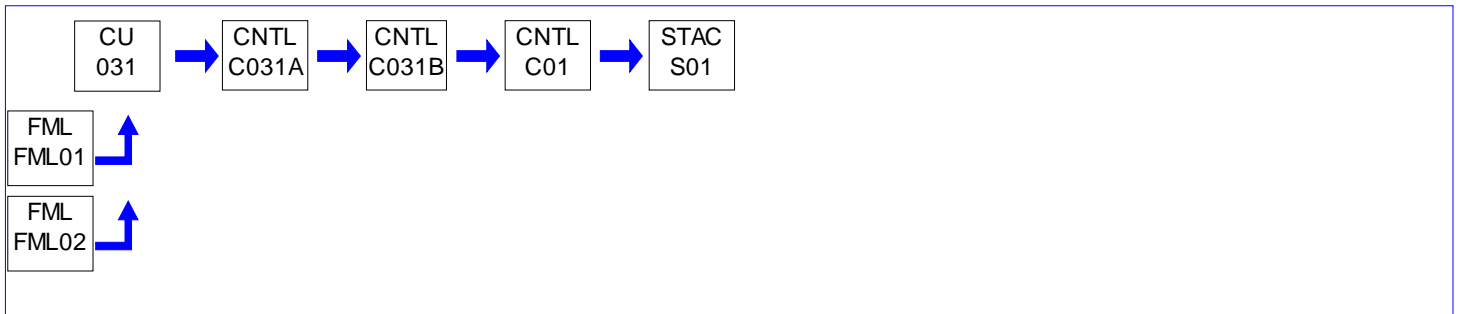
**I. RESTRICTIONS.****Emission Restriction(s).****# 001 [25 Pa. Code §127.441]****Operating permit terms and conditions.**

[Additional authority for this permit condition is derived from 25 Pa. Code Sections 127.1 and 127.12]

[Compliance with the requirement specified in part (a) of this streamlined permit condition assures compliance with 25 Pa. Code Section 123.22. Compliance with the requirement specified in part (d) of this streamlined permit condition assures compliance with 25 Pa. Code Section 123.11.]

- (a) The emission of sulfur oxides (SO<sub>x</sub>), expressed as SO<sub>2</sub>, from Source ID 031 shall not exceed 0.025 pound per million Btu heat input.
- (b) The emission of carbon monoxide (CO) from Source ID 031 shall not exceed 0.30 pound per million Btu heat input.
- (c) The emission of nitrogen oxides (NO<sub>x</sub>), expressed as NO<sub>2</sub>, from Source ID 031 shall not exceed 0.21 pound per million Btu heat input.
- (d) The emission of particulate matter from Source ID 031 shall not exceed 0.2 pound per million Btu heat input.
- (e) The emission of volatile organic compounds (VOCs) from Source ID 031 shall not exceed 0.012 pound per million Btu heat input.

**Fuel Restriction(s).****# 002 [25 Pa. Code §127.441]****Operating permit terms and conditions.**

[Additional authority for this permit condition is derived from 25 Pa. Code Sections 127.1 and 127.12]

- (a) The permittee shall only use natural gas or kiln dried wood waste with a composite lumber content of not greater than 5 percent by weight as fuel for Source ID 031, except that a mixture of green wood waste and kiln dried wood waste may be fired provided the total firing time of this mixture shall not exceed 336 hours in any 12 consecutive month period, combined for Source IDs 031 and 032, i.e. if Source IDs 031 and 032 are ever fired simultaneously with the green wood waste mixture, each hour of simultaneous firing shall count as two hours.
- (b) Mixtures of green wood waste and kiln dried wood waste fired by the boiler may not be greater than 30% green wood waste, by weight.
- (c) At no time shall any composite lumber which has vinyl or other plastic laminate attached be burned in Source ID 031.

**SECTION D. Source Level Requirements****II. TESTING REQUIREMENTS.****# 003 [25 Pa. Code §127.441]****Operating permit terms and conditions.**

(a) By no later than February 28, 2026, the permittee shall perform testing on the exhaust of Source ID 031 to verify the nitrogen oxide, carbon monoxide, and particulate matter, including particulate matter less than 10 micron, emission rates, as well as the opacity.

(b) All testing shall be performed while Source ID 031 is operating at its maximum routine operating conditions, while being fired on a fuel composition representative of routine operation of the boiler, using test methods and procedures approved by the Department.

(c) With respect to the carbon monoxide and nitrogen oxide testing, Source ID 031 shall be tested individually either via testing at a stack location that samples only the emissions from Source ID 031, or if sampled at the final exhaust point downstream of control device C01, while Source ID 032 is not in operation.

(d) With respect to the particulate matter testing, the permittee shall conduct the testing at the final exhaust point downstream of control device C01 (since both boilers share control device C01) while both Source ID's 031 and 032 are operating at their maximum routine operating conditions per 25 Pa. Code Section 139.11(1). The results of this testing shall apply to both sources.

**III. MONITORING REQUIREMENTS.****# 004 [25 Pa. Code §127.441]****Operating permit terms and conditions.**

[Additional authority for this permit condition is derived from 25 Pa. Code Sections 127.1 and 127.12]

The electrostatic precipitator (ID C01) associated with Source ID 031 shall be equipped with instrumentation that shall monitor and record the following parameters on a continuous basis:

- (a) Primary voltage,
- (b) Primary current,
- (c) Secondary voltage,
- (d) Secondary current,
- (e) Spark rate.

**# 005 [25 Pa. Code §127.441]****Operating permit terms and conditions.**

[Additional authority for this permit condition is derived from 25 Pa. Code Sections 127.1 and 127.12]

Each multiclone (IDs C031A and C031B) associated with Source ID 031 shall be equipped with instrumentation to monitor the pressure differential across the multiclone on a continuous basis.

**# 006 [25 Pa. Code §127.441]****Operating permit terms and conditions.**

[Additional authority for this permit condition is derived from 25 Pa. Code Sections 127.1 and 127.12]

(a) Source ID 031 shall be equipped with oxygen monitors as described in the application and supplemental materials submitted for Plan Approval #08-318-027.

(b) The oxygen monitors must be in operable condition at any time Source ID 031 is in operation.

**SECTION D. Source Level Requirements****IV. RECORDKEEPING REQUIREMENTS.****# 007 [25 Pa. Code §127.441]****Operating permit terms and conditions.**

(a) The permittee shall keep the following records, on a monthly basis, for the electrostatic precipitator (ID C01) associated with Source ID 031:

- (1) Primary voltage,
- (2) Primary current,
- (3) Secondary voltage,
- (4) Secondary current,
- (5) Spark rate.

(b) These records shall be retained for a minimum of five (5) years and shall be made available to the Department upon request.

**# 008 [25 Pa. Code §127.441]****Operating permit terms and conditions.**

[Additional authority for this permit condition is derived from 25 Pa. Code Sections 127.1 and 127.12]

(a) The permittee shall keep the following records on a monthly basis:

- (1) Total quantities of natural gas, green wood wastes, kiln dried wood wastes, and composite lumber wastes burned in Source ID 031,
- (2) Total hours that a mixture of green wood waste and kiln dried wood waste is burned in Source ID 031.

(b) These records shall be retained for a minimum of five (5) years and shall be made available to the Department upon request.

**# 009 [40 CFR Part 60 Standards of Performance for New Stationary Sources §40 CFR 60.48c]****Subpart Dc - Standards of Performance for Small Industrial- Commercial-Institutional Steam Generating Units Reporting and recordkeeping requirements.**

The permittee shall comply with all applicable recordkeeping requirements as specified in 40 CFR Part 60 Subpart Dc Section 60.48c for Source ID 031.

**# 010 [40 CFR Part 63 NESHAPS for Source Categories §40 CFR 63.11225]****SUBPART JJJJJJ - National Emission Standards for Hazardous Air Pollutants for Industrial, Commercial, and Institutional Boilers Area Sources****What are my notification, reporting, and recordkeeping requirements?**

The permittee shall comply with the applicable recordkeeping requirements of 40 CFR 63.11225.

**V. REPORTING REQUIREMENTS.****# 011 [25 Pa. Code §127.441]****Operating permit terms and conditions.**

(a) The permittee shall submit reports to the Department on a semi-annual basis that include the records of following:

- (1) Total quantities of natural gas, green wood wastes, kiln dried wood wastes, and composite lumber wastes burned in Source ID 031 per month,
- (2) Total hours that a mixture of green wood waste and kiln dried wood waste is burned in Source ID 031 per month.

(b) The semi-annual reports shall be submitted to the Department by no later than March 1 (for January 1 through December



**SECTION D. Source Level Requirements**

31 of the previous year) and September 1 (for July 1 of the previous year through June 30 of the current year).

**# 012 [25 Pa. Code §127.441]****Operating permit terms and conditions.**

The submission of all requests, reports, application submittals, and other communications required by NSPS Subpart Dc and NESHAPs Subpart JJJJJJ must be made to both the U.S. Environmental Protection Agency and the Pennsylvania Department of Environmental Protection. The copies may be sent to:

R3\_Air\_Apps\_and\_Notices@epa.gov

and

The Pennsylvania Department of Environmental Protection  
Air Quality Program Manager  
208 W. Third Street, Suite 101  
Williamsport, PA 17701-6448

**# 013 [40 CFR Part 60 Standards of Performance for New Stationary Sources §40 CFR 60.48c]****Subpart Dc - Standards of Performance for Small Industrial- Commercial-Institutional Steam Generating Units Reporting and recordkeeping requirements.**

The permittee shall comply with all applicable reporting requirements as specified in 40 CFR Part 60 Subpart Dc Section 60.48c for Source ID 031.

**# 014 [40 CFR Part 63 NESHAPS for Source Categories §40 CFR 63.11225]****SUBPART JJJJJJ - National Emission Standards for Hazardous Air Pollutants for Industrial, Commercial, and Institutional Boilers Area Sources****What are my notification, reporting, and recordkeeping requirements?**

The permittee shall comply with the applicable notification and reporting requirements of 40 CFR 63.11225.

**VI. WORK PRACTICE REQUIREMENTS.****# 015 [25 Pa. Code §127.441]****Operating permit terms and conditions.**

[Additional authority for this permit condition is derived from 25 Pa. Code Sections 127.1 and 127.12]

Source ID 031 shall utilize staged combustion and flue gas recirculation as nitrogen oxide reduction techniques.

**# 016 [25 Pa. Code §127.441]****Operating permit terms and conditions.**

[Additional authority for this permit condition is derived from 25 Pa. Code Sections 127.1 and 127.12]

The permittee shall not operate Source ID 031 without the simultaneous operation of the multiclones (IDs C031A and C031B) and the electrostatic precipitator (ID C01). The only exception is that the permittee need not run the electrostatic precipitator (ID C01) associated with Source ID 031 when Source ID 031 is being operated as follows:

- (a) The boiler is being fired only on natural gas.
- (b) There is no wood waste fuel remaining in the boiler fireboxes.

**# 017 [40 CFR Part 63 NESHAPS for Source Categories §40 CFR 63.11205]****SUBPART JJJJJJ - National Emission Standards for Hazardous Air Pollutants for Industrial, Commercial, and Institutional Boilers Area Sources****What are my general requirements for complying with this subpart?**

Source ID 031 and all related air cleaning devices shall be maintained and operated in accordance with good air pollution control practices for minimizing emissions.

**SECTION D. Source Level Requirements****# 018 [40 CFR Part 63 NESHAPS for Source Categories §40 CFR 63.11223]****SUBPART JJJJJJ - National Emission Standards for Hazardous Air Pollutants for Industrial, Commercial, and Institutional Boilers Area Sources****How do I demonstrate continuous compliance with the work practice and management practice standards?**

The permittee shall perform tune-ups on Source ID 031 biennially, no more than 25 months after the previous tune-up. The performance tune-ups shall include the following:

- (a) As applicable, inspect the burner, and clean or replace any components of the burner as necessary.
- (b) Inspect the flame pattern, as applicable, and adjust the burner as necessary to optimize the flame pattern. The adjustment should be consistent with the manufacturer's specifications, if available.
- (c) Inspect the system controlling the air-to-fuel ratio, as applicable, and ensure that it is correctly calibrated and functioning properly.
- (d) Optimize total emissions of CO. This optimization should be consistent with the manufacturer's specifications, if available.
- (e) Measure the concentrations in the effluent stream of CO in parts per million, by volume, and oxygen in volume percent, before and after the adjustments are made (measurements may be either on a dry or wet basis, as long as it is the same basis before and after the adjustments are made). Measurements may be taken using a portable CO analyzer.
- (f) Maintain on-site and submit, if requested by the Administrator, a report containing the following information:
  - (1) The concentrations of CO in the effluent stream in parts per million, by volume, and oxygen in volume percent, measured at high fire or typical operating load, before and after the tune-up of the boiler.
  - (2) A description of any corrective actions taken as a part of the tune-up of the boiler.
  - (3) The type and amount of fuel used over the 12 months prior to the tune-up of the boiler, but only if the unit was physically and legally capable of using more than one type of fuel during that period. Units sharing a fuel meter may estimate the fuel use by each unit.
- (g) If the unit is not operating on the required date for a tune-up, the tune-up must be conducted within 30 days of startup.

**VII. ADDITIONAL REQUIREMENTS.****# 019 [25 Pa. Code §127.441]****Operating permit terms and conditions.**

- (a) Source ID 031 is a Hurst Boiler and Welding Co. model M-4000 boiler, rated at 28.7 million Btu per hour, natural gas (backup) and wood waste fired, located in the boiler room.
- (b) ID C031A is a Hurst Boiler and Welding Co. model 12K-1CT primary multiclone, vents to the secondary multiclone, located in the boiler room.
- (c) ID C031B is a Hurst Boiler and Welding Co. model 6UP-44T secondary multiclone, vents to the electrostatic precipitator, located in the boiler room.
- (d) ID C01 is a PPC Industries model XH-1212-2S electrostatic precipitator, dry single stage unit, stack rated at 25,100 ACFM and 14,400 SCFM, located outside the boiler room.

**# 020 [25 Pa. Code §127.441]****Operating permit terms and conditions.**

[Additional authority for this permit condition is derived from 25 Pa. Code Sections 127.1 and 127.12]

The electrostatic precipitator (ID C01) associated with Source ID 031 shall be equipped with two transformer/rectifier sets

**SECTION D. Source Level Requirements**

and each set shall provide not less than 183.3 kilovolt-amps of power.

**# 021 [25 Pa. Code §127.441]****Operating permit terms and conditions.**

The electrostatic precipitator (ID C01) associated with Source ID 031 shall be located downstream of the primary and secondary multiclones (IDs C031A and C031B) associated with Source ID 031.

**# 022 [40 CFR Part 60 Standards of Performance for New Stationary Sources §40 CFR 60.40c]****Subpart Dc - Standards of Performance for Small Industrial- Commercial-Institutional Steam Generating Units  
Applicability and delegation of authority.**

Source ID 031 is subject to 40 CFR Part 60, Subpart Dc. The permittee shall comply with all the applicable requirements specified in 40 CFR Sections 60.40c through 60.48c.

**# 023 [40 CFR Part 63 NESHAPS for Source Categories §40 CFR 63.11193]****SUBPART JJJJJJ - National Emission Standards for Hazardous Air Pollutants for Industrial, Commercial, and Institutional Boilers Area Sources****Am I subject to this subpart?**

Source ID 031 is subject to 40 CFR Part 63 Subpart JJJJJJ. The permittee shall comply with all the applicable requirements specified in 40 CFR Sections 63.11193 through 63.11237.

**SECTION D. Source Level Requirements**

Source ID: 032

Source Name: BOILER 2

Source Capacity/Throughput: 28.700 MMBTU/HR

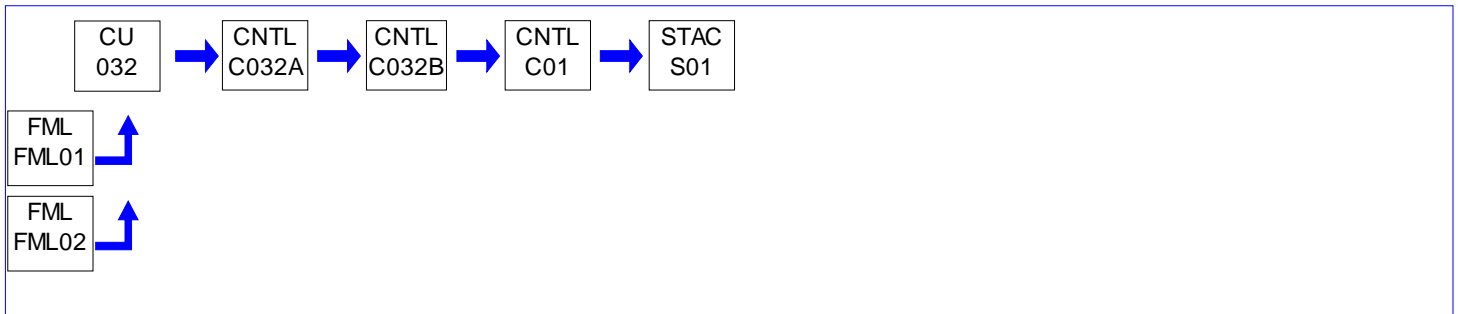
**I. RESTRICTIONS.****Emission Restriction(s).****# 001 [25 Pa. Code §127.441]****Operating permit terms and conditions.**

[Additional authority for this permit condition is derived from 25 Pa. Code Sections 127.1 and 127.12]

[Compliance with the requirement specified in part (a) of this streamlined permit condition assures compliance with 25 Pa. Code Section 123.22. Compliance with the requirement specified in part (d) of this streamlined permit condition assures compliance with 25 Pa. Code Section 123.11.]

- (a) The emission of sulfur oxides (SO<sub>x</sub>), expressed as SO<sub>2</sub>, from Source ID 032 shall not exceed 0.025 pound per million Btu heat input.
- (b) The emission of carbon monoxide (CO) from Source ID 032 shall not exceed 0.30 pound per million Btu heat input.
- (c) The emission of nitrogen oxides (NO<sub>x</sub>), expressed as NO<sub>2</sub>, from Source ID 032 shall not exceed 0.21 pound per million Btu heat input.
- (d) The emission of particulate matter from Source ID 032 shall not exceed 0.2 pound per million Btu heat input.
- (e) The emission of volatile organic compounds (VOCs) from Source ID 032 shall not exceed 0.012 pound per million Btu heat input.

**Fuel Restriction(s).****# 002 [25 Pa. Code §127.441]****Operating permit terms and conditions.**

[Additional authority for this permit condition is derived from 25 Pa. Code Sections 127.1 and 127.12]

- (a) The permittee shall only use natural gas or kiln dried wood waste with a composite lumber content of not greater than 5 percent by weight as fuel for Source ID 032, except that a mixture of green wood waste and kiln dried wood waste may be fired provided the total firing time of this mixture shall not exceed 336 hours in any 12 consecutive month period, combined for Source IDs 031 and 032, i.e. if Source IDs 031 and 032 are ever fired simultaneously with the green wood waste mixture, each hour of simultaneous firing shall count as two hours.
- (b) Mixtures of green wood waste and kiln dried wood waste fired by the boiler may not be greater than 30% green wood waste, by weight.
- (c) At no time shall any composite lumber which has vinyl or other plastic laminate attached be burned in Source ID 032.

**SECTION D. Source Level Requirements****II. TESTING REQUIREMENTS.****# 003 [25 Pa. Code §127.441]****Operating permit terms and conditions.**

(a) By no later than February 28, 2026, the permittee shall perform testing on the exhaust of Source ID 032 to verify the nitrogen oxide, carbon monoxide, and particulate matter, including particulate matter less than 10 micron, emission rates, as well as the opacity.

(b) All testing shall be performed while Source ID 032 is operating at its maximum routine operating conditions, while being fired on a fuel composition representative of routine operation of the boiler, using test methods and procedures approved by the Department.

(c) With respect to the carbon monoxide and nitrogen oxide testing, Source ID 032 shall be tested individually either via testing at a stack location that samples only the emissions from Source ID 032, or if sampled at the final exhaust point downstream of control device C01, while Source ID 031 is not in operation.

(d) With respect to the particulate matter testing, the permittee shall conduct the testing at the final exhaust point downstream of control device C01 (since both boilers share control device C01) while both Source ID's 031 and 032 are operating at their maximum routine operating conditions per 25 Pa. Code Section 139.11(1). The results of this testing shall apply to both sources.

**III. MONITORING REQUIREMENTS.****# 004 [25 Pa. Code §127.441]****Operating permit terms and conditions.**

[Additional authority for this permit condition is derived from 25 Pa. Code Sections 127.1 and 127.12]

(a) Source ID 032 shall be equipped with oxygen monitors as described in the application and supplemental materials submitted for Plan Approval #08-318-027.

(b) The oxygen monitors must be in operable condition at any time Source ID 032 is in operation.

**# 005 [25 Pa. Code §127.441]****Operating permit terms and conditions.**

[Additional authority for this permit condition is derived from 25 Pa. Code Sections 127.1 and 127.12]

Each multiclone (IDs C032A and C032B) associated with Source ID 032 shall be equipped with instrumentation to monitor the pressure differential across the multiclone on a continuous basis.

**# 006 [25 Pa. Code §127.441]****Operating permit terms and conditions.**

[Additional authority for this permit condition is derived from 25 Pa. Code Sections 127.1 and 127.12]

The electrostatic precipitator (ID C01) associated with Source ID 032 shall be equipped with instrumentation that shall monitor and record the following parameters on a continuous basis:

(a) Primary voltage,

(b) Primary current,

(c) Secondary voltage,

(d) Secondary current,

(e) Spark rate.

**SECTION D. Source Level Requirements****IV. RECORDKEEPING REQUIREMENTS.****# 007 [25 Pa. Code §127.441]****Operating permit terms and conditions.**

[Additional authority for this permit condition is derived from 25 Pa. Code Sections 127.1 and 127.12]

(a) The permittee shall keep the following records on a monthly basis:

(1) Total quantities of natural gas, green wood wastes, kiln dried wood wastes, and composite lumber wastes burned in Source ID 032,

(2) Total hours that a mixture of green wood waste and kiln dried wood waste is burned in Source ID 032.

(b) These records shall be retained for a minimum of five (5) years and shall be made available to the Department upon request.

**# 008 [25 Pa. Code §127.441]****Operating permit terms and conditions.**

(a) The permittee shall keep the following records, on a monthly basis, for the electrostatic precipitator (ID C01) associated with Source ID 032:

(1) Primary voltage,

(2) Primary current,

(3) Secondary voltage,

(4) Secondary current,

(5) Spark rate.

(b) These records shall be retained for a minimum of five (5) years and shall be made available to the Department upon request.

**# 009 [40 CFR Part 60 Standards of Performance for New Stationary Sources §40 CFR 60.48c]****Subpart Dc - Standards of Performance for Small Industrial- Commercial-Institutional Steam Generating Units Reporting and recordkeeping requirements.**

The permittee shall comply with all applicable recordkeeping requirements as specified in 40 CFR Part 60 Subpart Dc Section 60.48c for Source ID 032.

**# 010 [40 CFR Part 63 NESHAPS for Source Categories §40 CFR 63.11225]****SUBPART JJJJJJ - National Emission Standards for Hazardous Air Pollutants for Industrial, Commercial, and Institutional Boilers Area Sources****What are my notification, reporting, and recordkeeping requirements?**

The permittee shall comply with the applicable recordkeeping requirements of 40 CFR 63.11225.

**V. REPORTING REQUIREMENTS.****# 011 [25 Pa. Code §127.441]****Operating permit terms and conditions.**

(a) The permittee shall submit reports to the Department on a semi-annual basis that include the records of following:

(1) Total quantities of natural gas, green wood wastes, kiln dried wood wastes, and composite lumber wastes burned in Source ID 032 per month,

(2) Total hours that a mixture of green wood waste and kiln dried wood waste is burned in Source ID 032 per month.

(b) The semi-annual reports shall be submitted to the Department by no later than March 1 (for January 1 through December

**SECTION D. Source Level Requirements**

31 of the previous year) and September 1 (for July 1 of the previous year through June 30 of the current year).

**# 012 [25 Pa. Code §127.441]****Operating permit terms and conditions.**

The submission of all requests, reports, application submittals, and other communications required by NSPS Subpart Dc and NESHAPs Subpart JJJJJJ must be made to both the U.S. Environmental Protection Agency and the Pennsylvania Department of Environmental Protection. The copies may be sent to:

R3\_Air\_Apps\_and\_Notices@epa.gov

and

The Pennsylvania Department of Environmental Protection  
Air Quality Program Manager  
208 W. Third Street, Suite 101  
Williamsport, PA 17701-6448

**# 013 [40 CFR Part 60 Standards of Performance for New Stationary Sources §40 CFR 60.48c]****Subpart Dc - Standards of Performance for Small Industrial- Commercial-Institutional Steam Generating Units Reporting and recordkeeping requirements.**

The permittee shall comply with all applicable reporting requirements as specified in 40 CFR Part 60 Subpart Dc Section 60.48c for Source ID 032.

**# 014 [40 CFR Part 63 NESHAPS for Source Categories §40 CFR 63.11225]****SUBPART JJJJJJ - National Emission Standards for Hazardous Air Pollutants for Industrial, Commercial, and Institutional Boilers Area Sources****What are my notification, reporting, and recordkeeping requirements?**

The permittee shall comply with the applicable notification and reporting requirements of 40 CFR 63.11225.

**VI. WORK PRACTICE REQUIREMENTS.****# 015 [25 Pa. Code §127.441]****Operating permit terms and conditions.**

[Additional authority for this permit condition is derived from 25 Pa. Code Sections 127.1 and 127.12]

Source ID 032 shall utilize staged combustion and flue gas recirculation as nitrogen oxide reduction techniques.

**# 016 [25 Pa. Code §127.441]****Operating permit terms and conditions.**

[Additional authority for this permit condition is derived from 25 Pa. Code Sections 127.1 and 127.12]

The permittee shall not operate Source ID 032 without the simultaneous operation of the multiclones (IDs C032A and C032B) and the electrostatic precipitator (ID C01). The only exception is that the permittee need not run the electrostatic precipitator (ID C01) associated with Source ID 032 when Source ID 032 is being operated as follows:

- (a) The boiler is being fired only on natural gas.
- (b) There is no wood waste fuel remaining in the boiler fireboxes.

**# 017 [40 CFR Part 63 NESHAPS for Source Categories §40 CFR 63.11205]****SUBPART JJJJJJ - National Emission Standards for Hazardous Air Pollutants for Industrial, Commercial, and Institutional Boilers Area Sources****What are my general requirements for complying with this subpart?**

Source ID 032 and all related air cleaning devices shall be maintained and operated in accordance with good air pollution control practices for minimizing emissions.

**SECTION D. Source Level Requirements****# 018 [40 CFR Part 63 NESHAPS for Source Categories §40 CFR 63.11223]****SUBPART JJJJJJ - National Emission Standards for Hazardous Air Pollutants for Industrial, Commercial, and Institutional Boilers Area Sources****How do I demonstrate continuous compliance with the work practice and management practice standards?**

The permittee shall perform tune-ups on Source ID 032 biennially, no more than 25 months after the previous tune-up. The performance tune-ups shall include the following:

- (a) As applicable, inspect the burner, and clean or replace any components of the burner as necessary.
- (b) Inspect the flame pattern, as applicable, and adjust the burner as necessary to optimize the flame pattern. The adjustment should be consistent with the manufacturer's specifications, if available.
- (c) Inspect the system controlling the air-to-fuel ratio, as applicable, and ensure that it is correctly calibrated and functioning properly.
- (d) Optimize total emissions of CO. This optimization should be consistent with the manufacturer's specifications, if available.
- (e) Measure the concentrations in the effluent stream of CO in parts per million, by volume, and oxygen in volume percent, before and after the adjustments are made (measurements may be either on a dry or wet basis, as long as it is the same basis before and after the adjustments are made). Measurements may be taken using a portable CO analyzer.
- (f) Maintain on-site and submit, if requested by the Administrator, a report containing the following information:
  - (1) The concentrations of CO in the effluent stream in parts per million, by volume, and oxygen in volume percent, measured at high fire or typical operating load, before and after the tune-up of the boiler.
  - (2) A description of any corrective actions taken as a part of the tune-up of the boiler.
  - (3) The type and amount of fuel used over the 12 months prior to the tune-up of the boiler, but only if the unit was physically and legally capable of using more than one type of fuel during that period. Units sharing a fuel meter may estimate the fuel use by each unit.
- (g) If the unit is not operating on the required date for a tune-up, the tune-up must be conducted within 30 days of startup.

**VII. ADDITIONAL REQUIREMENTS.****# 019 [25 Pa. Code §127.441]****Operating permit terms and conditions.**

The electrostatic precipitator (ID C01) associated with Source ID 032 shall be located downstream of the primary and secondary multiclones (IDs C032A and C032B) associated with Source ID 032.

**# 020 [25 Pa. Code §127.441]****Operating permit terms and conditions.**

- (a) Source ID 032 is a Hurst Boiler and Welding Co. model M-4000 boiler, rated at 28.7 million Btu per hour, natural gas (backup) and wood waste fired, located in the boiler room.
- (b) ID C032A is a Hurst Boiler and Welding Co. model 12K-1CT primary multiclone, vents to the secondary multiclone, located in the boiler room.
- (c) ID C032B is a Hurst Boiler and Welding Co. model 6UP-44T secondary multiclone, vents to the electrostatic precipitator, located in the boiler room.
- (d) ID C01 is a PPC Industries model XH-1212-2S electrostatic precipitator, dry single stage unit, stack rated at 25,100 ACFM, 14,400 SCFM, located outside the boiler room.



**SECTION D. Source Level Requirements****# 021 [25 Pa. Code §127.441]****Operating permit terms and conditions.**

[Additional authority for this permit condition is derived from 25 Pa. Code Sections 127.1 and 127.12]

The electrostatic precipitator (ID C01) associated with Source ID 032 shall be equipped with two transformer/rectifier sets and each set shall provide not less than 183.3 kilovolt-amperes of power.

**# 022 [40 CFR Part 60 Standards of Performance for New Stationary Sources §40 CFR 60.40c]****Subpart Dc - Standards of Performance for Small Industrial- Commercial-Institutional Steam Generating Units  
Applicability and delegation of authority.**

Source ID 032 is subject to 40 CFR Part 60, Subpart Dc. The permittee shall comply with all the applicable requirements specified in 40 CFR Sections 60.40c through 60.48c.

**# 023 [40 CFR Part 63 NESHAPS for Source Categories §40 CFR 63.11193]****SUBPART JJJJJJ - National Emission Standards for Hazardous Air Pollutants for Industrial, Commercial, and Institutional Boilers Area Sources****Am I subject to this subpart?**

Source ID 032 is subject to 40 CFR Part 63 Subpart JJJJJJ. The permittee shall comply with all the applicable requirements specified in 40 CFR Sections 63.11193 through 63.11237.

**SECTION D. Source Level Requirements**

Source ID: P101

Source Name: 8 OAK KILNS

Source Capacity/Throughput:

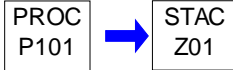
**I. RESTRICTIONS.**

No additional requirements exist except as provided in other sections of this permit including Section B (State Only General Requirements).

**II. TESTING REQUIREMENTS.**

No additional testing requirements exist except as provided in other sections of this permit including Section B (State Only General Requirements).

**III. MONITORING REQUIREMENTS.**

No additional monitoring requirements exist except as provided in other sections of this permit including Section B (State Only General Requirements).

**IV. RECORDKEEPING REQUIREMENTS.****# 001 [25 Pa. Code §127.441]****Operating permit terms and conditions.**

(a) The permittee shall keep records, on a monthly basis, of the total amount of lumber in board feet processed in Source ID P101.

(b) These records shall be retained for a minimum of five (5) years and shall be made available to the Department upon request.

**V. REPORTING REQUIREMENTS.****# 002 [25 Pa. Code §127.441]****Operating permit terms and conditions.**

(a) The permittee shall submit reports to the Department on a semi-annual basis that include the records of the total amount of lumber in board feet processed in Source ID P101.

(b) The semi-annual reports shall be submitted to the Department by no later than March 1 (for January 1 through December 31 of the previous year) and September 1 (for July 1 of the previous year through June 30 of the current year).

**VI. WORK PRACTICE REQUIREMENTS.**

No additional work practice requirements exist except as provided in other sections of this permit including Section B (State Only General Requirements).

**VII. ADDITIONAL REQUIREMENTS.****# 003 [25 Pa. Code §127.441]****Operating permit terms and conditions.**

Source ID P101 consists of eight (8) SII Kilns oak drying kilns, custom built, heated by steam from Source IDs 031 and 032, rated at 29.1 million board feet per year total, located in kiln buildings area.

**SECTION D. Source Level Requirements**

Source ID: P102

Source Name: 10 MAPLE KILNS

Source Capacity/Throughput:

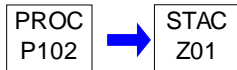
**I. RESTRICTIONS.**

No additional requirements exist except as provided in other sections of this permit including Section B (State Only General Requirements).

**II. TESTING REQUIREMENTS.**

No additional testing requirements exist except as provided in other sections of this permit including Section B (State Only General Requirements).

**III. MONITORING REQUIREMENTS.**

No additional monitoring requirements exist except as provided in other sections of this permit including Section B (State Only General Requirements).

**IV. RECORDKEEPING REQUIREMENTS.****# 001 [25 Pa. Code §127.441]****Operating permit terms and conditions.**

(a) The permittee shall keep records, on a monthly basis, of the total amount of lumber in board feet processed in Source ID P102.

(b) These records shall be retained for a minimum of five (5) years and shall be made available to the Department upon request.

**V. REPORTING REQUIREMENTS.****# 002 [25 Pa. Code §127.441]****Operating permit terms and conditions.**

(a) The permittee shall submit reports to the Department on a semi-annual basis that include the records of the total amount of lumber in board feet processed in Source ID P102.

(b) The semi-annual reports shall be submitted to the Department by no later than March 1 (for January 1 through December 31 of the previous year) and September 1 (for July 1 of the previous year through June 30 of the current year).

**VI. WORK PRACTICE REQUIREMENTS.**

No additional work practice requirements exist except as provided in other sections of this permit including Section B (State Only General Requirements).

**VII. ADDITIONAL REQUIREMENTS.****# 003 [25 Pa. Code §127.441]****Operating permit terms and conditions.**

Source ID P102 consists of ten (10) SII Kilns maple drying kilns, custom built, heated by steam from Source IDs 031 and 032, rated at 26 million board feet per year total, located in kiln buildings area.

**SECTION D. Source Level Requirements**

Source ID: P103

Source Name: WOODWORKING SOURCES

Source Capacity/Throughput:

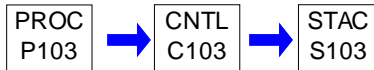
**I. RESTRICTIONS.****Emission Restriction(s).****# 001 [25 Pa. Code §127.441]****Operating permit terms and conditions.**

[Additional authority for this permit condition is derived from 25 Pa. Code Sections 127.1 and 127.12]

{Compliance with the requirement specified in this streamlined permit condition assures compliance with the provision in 25 Pa. Code Section 123.13}

No person may permit the emission of particulate matter from the exhaust of each fabric collector (ID C103) associated with Source ID P103 into the outdoor atmosphere in a manner that the concentration in the effluent gas exceeds 0.005 grain per dry standard cubic foot.

**II. TESTING REQUIREMENTS.**

No additional testing requirements exist except as provided in other sections of this permit including Section B (State Only General Requirements).

**III. MONITORING REQUIREMENTS.****# 002 [25 Pa. Code §127.441]****Operating permit terms and conditions.**

[Additional authority for this permit condition is derived from 25 Pa. Code Sections 127.1 and 127.12]

Each fabric collector (ID C103) associated with Source ID P103 shall be equipped with instrumentation to monitor the pressure differential across the fabric collector bags on a continuous basis.

**IV. RECORDKEEPING REQUIREMENTS.****# 003 [25 Pa. Code §127.441]****Operating permit terms and conditions.**

(a) The permittee shall keep records of the pressure differential across each fabric collector (ID C103) associated with Source ID P103 at least once per shift when Source ID P103 is in operation.

(b) These records shall be retained for a minimum of five (5) years and shall be made available to the Department upon request.

**V. REPORTING REQUIREMENTS.**

No additional reporting requirements exist except as provided in other sections of this permit including Section B (State Only General Requirements).

**VI. WORK PRACTICE REQUIREMENTS.****# 004 [25 Pa. Code §127.441]****Operating permit terms and conditions.**

The permittee shall keep on hand a sufficient quantity of spare fabric collector bags for each fabric collector (ID C103) associated with Source ID P103 in order to be able to immediately replace any bags requiring replacement due to

**SECTION D. Source Level Requirements**

deterioration.

**# 005 [25 Pa. Code §127.441]****Operating permit terms and conditions.**

(a) Pursuant to the Best Available Technology provisions of 25 Pa. Code Sections 127.1 and 127.12, the permittee shall not operate any of the woodworking equipment operating under Source ID P103 without the simultaneous operation of the associated fabric collectors (ID C103). The particulate matter emissions from the woodworking equipment operating under Source ID P103 shall be controlled by ID C103.

(b) The permittee, at its discretion, may vent the Zeno model ZTLL woodwaste grinder to fabric collector #5.

**VII. ADDITIONAL REQUIREMENTS.****# 006 [25 Pa. Code §127.441]****Operating permit terms and conditions.**

(a) Source ID P103 consists of the following:

- (1) various woodworking equipment located throughout the main plant;
- (2) one Zeno model ZTLL woodwaste grinder (approved via RFD on August 2, 2016);
- (3) a wood stabilizer application operation (approved via RFD on June 9, 2016).

(b) ID C103 consists of five (5) Torit and Day model 484RF12 fabric collectors, reverse-air cleaning with pressure gauge, rated at 72,000 ACFM and SCFM each, total of approximately 60 pickups throughout the facility, located outside the main plant. The fifth such fabric collector (#5) was approved via RFD on December 17, 2013.

**SECTION D. Source Level Requirements**

Source ID: P104

Source Name: WOOD WASTE STORAGE SILO

Source Capacity/Throughput:

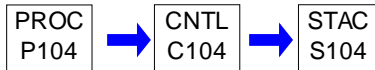
**I. RESTRICTIONS.****Emission Restriction(s).**

# 001 [25 Pa. Code §127.441]

**Operating permit terms and conditions.**

[Additional authority for this permit condition is derived from 25 Pa. Code Sections 127.1 and 127.12]

{Compliance with the requirement specified in this streamlined permit condition assures compliance with the provision in 25 Pa. Code Section 123.13}

No person may permit the emission of particulate matter from the exhaust of the fabric collector (ID C104) associated with Source ID P104 into the outdoor atmosphere in a manner that the concentration in the effluent gas exceeds 0.02 grain per dry standard cubic foot.

**Throughput Restriction(s).**

# 002 [25 Pa. Code §127.441]

**Operating permit terms and conditions.**

[Additional authority for this permit condition is derived from 25 Pa. Code Sections 127.1 and 127.12]

Source ID P104 shall never at any time contain more than 5 percent by weight of composite lumber waste.

**II. TESTING REQUIREMENTS.**

No additional testing requirements exist except as provided in other sections of this permit including Section B (State Only General Requirements).

**III. MONITORING REQUIREMENTS.**

# 003 [25 Pa. Code §127.441]

**Operating permit terms and conditions.**

[Additional authority for this permit condition is derived from 25 Pa. Code Sections 127.1 and 127.12]

The fabric collector (ID C104) associated with Source ID P104 shall be equipped with instrumentation to monitor the pressure differential across the fabric collector bags on a continuous basis.

**IV. RECORDKEEPING REQUIREMENTS.**

# 004 [25 Pa. Code §127.441]

**Operating permit terms and conditions.**

(a) The permittee shall keep records of the pressure differential across the fabric collector (ID C104) associated with Source ID P104 at least once per shift when ID C104 is in operation.

(b) These records shall be retained for a minimum of five (5) years and shall be made available to the Department upon request.

**SECTION D. Source Level Requirements****V. REPORTING REQUIREMENTS.**

No additional reporting requirements exist except as provided in other sections of this permit including Section B (State Only General Requirements).

**VI. WORK PRACTICE REQUIREMENTS.****# 005 [25 Pa. Code §127.441]****Operating permit terms and conditions.**

The permittee shall keep on hand a sufficient quantity of spare fabric collector bags for the fabric collector (ID C104) associated with Source ID P104 in order to be able to immediately replace any bags requiring replacement due to deterioration.

**# 006 [25 Pa. Code §127.441]****Operating permit terms and conditions.**

[Additional authority for this permit condition is derived from 25 Pa. Code Sections 127.1 and 127.12]

The permittee shall not operate Source ID P104 without the simultaneous operation of the fabric collector (ID C104). The particulate matter emissions from Source ID P104 shall be controlled by ID C104.

**VII. ADDITIONAL REQUIREMENTS.****# 007 [25 Pa. Code §127.441]****Operating permit terms and conditions.**

(a) Source ID P104 is a wood waste storage silo with a 12,862 cubic foot capacity.

(b) ID C104 is a Torit and Day model 156RFW8 fabric collector, rated at 10,520 ACFM and SCFM, located on top of the wood waste storage silo.

**SECTION D. Source Level Requirements**

Source ID: P105

Source Name: COMPONENT COATING, TOPCOAT, &amp; CLEAN-UP

Source Capacity/Throughput:

**I. RESTRICTIONS.****Emission Restriction(s).****# 001 [25 Pa. Code §123.13]****Processes**

No person may permit the emission of particulate matter from the exhaust of the regenerative thermal oxidizer (ID C105) associated with Source ID P105 into the outdoor atmosphere in a manner that the concentration in the effluent gas exceeds 0.04 grain per dry standard cubic foot.

**# 002 [25 Pa. Code §123.21]****General**

No person may permit the emission into the outdoor atmosphere of sulfur oxides, expressed as SO<sub>2</sub>, from the exhaust of the regenerative thermal oxidizer (ID C105) associated with Source ID P105 in a manner that the concentration of the sulfur oxides in the effluent gas exceeds 500 parts per million, by volume, dry basis.

**# 003 [25 Pa. Code §127.441]****Operating permit terms and conditions.**

[Additional authority for this permit condition is derived from 25 Pa. Code Sections 127.1 and 127.12]

(a) All stains, other than glazing stains, shall have a VOC content of not greater than 6.8 pounds per gallon, minus water and as mixed for application.

(b) All topcoats and sealers shall have a VOC content of not greater than 5.2 pounds per gallon, minus water and as mixed for application.

(c) All glazing stains shall have a VOC content of not greater than 5.6 pounds per gallon, minus water and as mixed for application.

(d) None of the materials used in Source ID P105 shall contain formaldehyde except sealers, topcoats, and glazing stains.

(1) The formaldehyde content of all sealers and topcoats shall not exceed 0.20 percent by weight.

(2) The formaldehyde content of all glazing stains shall not exceed 0.10 percent by weight.

(e) None of the materials used in Source ID P105 shall contain methylene chloride, 1,1,1-trichloroethane, or any other halogenated compound.

(f) None of the materials used in Source ID P105 shall contain any sulfonated compound other than toluene sulfuric acid (TSA) or other sulfonated catalysts, as approved by the Department on October 13, 2016.

**# 004 [25 Pa. Code §129.102]****Emission Standards**

[Compliance with the requirement specified in this streamlined permit condition assures compliance with the provision in 25 Pa. Code Section 129.52(b)(2)]

The permittee shall limit volatile organic compound (VOC) emissions from Source ID P105 by using the regenerative thermal oxidizer (ID C105) that will achieve a reduction in emissions equivalent to 0.8 lb VOC/lb solids for waterborne



**SECTION D. Source Level Requirements**

topcoats, or 1.8 lbs VOC/lb solids for topcoats and 1.9 lbs VOC/lb solids for sealers that are used within a coating system shown in Table IV of 25 Pa. Code Section 129.102.

**Fuel Restriction(s).**

**# 005 [25 Pa. Code §127.441]**

**Operating permit terms and conditions.**

The permittee shall only use natural gas as fuel for ID C105.

**Control Device Efficiency Restriction(s).**

**# 006 [25 Pa. Code §127.441]**

**Operating permit terms and conditions.**

[Additional authority for this permit condition is derived from 25 Pa. Code Sections 127.1 and 127.12]

The finishing room shall provide 100 percent capture of all air contaminant emissions from Source ID P105.

**# 007 [25 Pa. Code §127.441]**

**Operating permit terms and conditions.**

[Additional authority for this permit condition is derived from 25 Pa. Code Sections 127.1 and 127.12]

The regenerative thermal oxidizer (ID C105) shall provide at least a 98 percent VOC destruction efficiency.

**II. TESTING REQUIREMENTS.**

**# 008 [25 Pa. Code §127.441]**

**Operating permit terms and conditions.**

(a) Within 180 days of reactivation of Source ID P105, the permittee shall perform testing on the inlet and outlet of ID C105 associated with Source ID P105 to verify the VOC destruction efficiency of ID C105.

(b) All testing shall be performed while Source ID P105 is operating at a representative rate of production, using test methods and procedures approved by the Department.

(c) During the stack testing, the temperature set-point of the combustion chamber of ID C105 shall be 1,600 degrees Fahrenheit and the actual instantaneous temperature of the combustion chamber of ID C105 shall not go below 1,550 degrees Fahrenheit.

**# 009 [25 Pa. Code §129.104]**

**Compliance procedures and monitoring requirements.**

[Compliance with the requirement specified in this streamlined permit condition assures compliance with the provision in 25 Pa. Code Section 129.52(b)(2)]

(a) The permittee shall calculate the required overall control efficiency needed to demonstrate compliance using the following equation:

$$O = (1 - E/C) * 100$$

Where:

C = the VOC content of the as applied coating, lbs VOC/lb solids

E = The emission limit, specified in Table IV of 25 Pa. Code Section 129.102, which shall be achieved by the affected emission point, lbs VOC/lb solids

**SECTION D. Source Level Requirements**

O = The overall control efficiency of the control system, expressed as a percentage

(b) The permittee shall document that the value of C in the equation above is obtained from the VOC and solids content of the as applied coating.

(c) The permittee shall demonstrate that the value of O calculated by the equation above is less than or equal to 98 percent.

**III. MONITORING REQUIREMENTS.****# 010 [25 Pa. Code §127.441]****Operating permit terms and conditions.**

[Additional authority for this permit condition is derived from 25 Pa. Code Sections 127.1 and 127.12]

The regenerative thermal oxidizer (ID C105) associated with Source ID P105 shall be equipped with a temperature monitoring and recording system that will accurately monitor and record the temperature of ID C105 on a continuous basis.

**# 011 [25 Pa. Code §127.441]****Operating permit terms and conditions.**

[Additional authority for this permit condition is derived from 25 Pa. Code Sections 127.1 and 127.12]

The regenerative thermal oxidizer (ID C105) associated with Source ID P105 shall be equipped with an alarm that will alert the operator should the oxidizer temperature drop below 1,560 degrees Fahrenheit or climb above a pre-set maximum oxidizer temperature. Should a low temperature or high temperature incident occur, all operations of Source ID P105 shall be shut down until ID C105 is operating in compliance with all applicable requirements.

**# 012 [25 Pa. Code §127.441]****Operating permit terms and conditions.**

[Additional authority for this permit condition is derived from 25 Pa. Code Sections 129.52 and 129.104]

The permittee shall calculate the VOC content of the as applied coatings used in Source ID P105, expressed in units of weight of VOC per weight of coating solids, as follows:

$$\text{VOC} = (\text{Wo})/(\text{Wn})$$

Where:

VOC = VOC content in lb VOC/lb of coating solids

Wo = Weight percent of VOC (Wv-Ww-Wex)

Wv = Weight percent of total volatiles (100% - weight percent solids)

Ww = Weight percent of water

Wex = Weight percent of exempt solvents

Wn = Weight percent of solids of the as applied coating

**IV. RECORDKEEPING REQUIREMENTS.****# 013 [25 Pa. Code §127.441]****Operating permit terms and conditions.**

[Additional authority for this permit condition is derived from 25 Pa. Code Sections 127.1 and 127.12]

(a) The permittee shall keep records of the temperature of the regenerative thermal oxidizer (ID C105) associated with Source ID P105.

**SECTION D. Source Level Requirements**

(b) These records shall be retained for a minimum of five (5) years and shall be made available to the Department upon request.

**# 014 [25 Pa. Code §127.441]****Operating permit terms and conditions.**

[Additional authority for this permit condition is derived from 25 Pa. Code Sections 129.104(a)(2)(ii) and 129.105(d)(1)]

The permittee shall maintain documentation from the supplier/manufacturer (e.g., certified product data sheets) which certifies the volatile organic compound (VOC) and hazardous air pollutant (HAP) content of each VOC and HAP containing material used in Source ID P105.

**# 015 [25 Pa. Code §127.441]****Operating permit terms and conditions.**

[Additional authority for this permit condition is derived from 25 Pa. Code Sections 129.52, 127.1, and 127.12]

(a) The permittee shall maintain daily and monthly records of the following for Source ID P105:

(1) The following parameters for each VOC-containing material as supplied for use in Source ID P105:

(i) The VOC-containing material name, classification (stain, sealer, topcoat, solvent, etc.), and identification number.

(ii) The volume used.

(iii) The mix ratio.

(iv) The density or specific gravity.

(v) The weight percent of total volatiles, water, solids, and exempt solvents.

(2) The VOC content (lbs VOC/lb solids and lb VOC/gal material, minus water) of each VOC-containing material as supplied.

(3) The VOC content (lbs VOC/lb solids and lb VOC/gal coating, minus water) of each as applied coating.

(4) The content of each individual hazardous air pollutant (lbs HAP/gal material, minus water) of each HAP-containing material.

(b) If any material used is mixed on site from multiple components rather than used exactly as received from the vendor, for each separate batch of such material a record shall be maintained of the following:

(1) The date the batch was mixed,

(2) The identity of each component used,

(3) The amount of each component used,

(4) The VOC content (lbs VOC/lb solids and lb VOC/gal material, minus water) of each component used,

(5) The VOC content (lbs VOC/lb solids and lb VOC/gal material, minus water) of the resultant mixed material.

(c) These records shall be retained for a minimum of five (5) years and shall be made available to the Department upon request.

**# 016 [25 Pa. Code §129.105]****Recordkeeping requirements**

(a) The permittee shall keep the following records on a monthly basis:

**SECTION D. Source Level Requirements**

(1) Copies of the calculations to support the equivalency of using a control system, as well as the data that are necessary to support the calculation of C and E in Section 129.104(a)(2)(i) and O in Section 129.104(a)(2)(iii).

(2) Records of the daily average value of each continuously monitored parameter for each operating day. If all recorded values for a monitored parameter are within the range established during the initial performance test, the permittee may record that all values are within the range rather than calculating and recording an average for that day.

(b) These records shall be retained for a minimum of five (5) years and shall be made available to the Department upon request.

**# 017 [25 Pa. Code §129.105]****Recordkeeping requirements**

(a) The permittee shall maintain a copy of the compliance certifications submitted in accordance with 25 Pa. Code Section 129.106(b) (relating to reporting requirements) for each semiannual period.

(b) The permittee shall maintain a copy of the other information submitted with the initial status report required by 25 Pa. Code Section 129.106(a) and the semiannual reports required by 25 Pa. Code Section 129.106(b).

(c) These records shall be retained for a minimum of five (5) years and shall be made available to the Department upon request.

**# 018 [25 Pa. Code §129.105]****Recordkeeping requirements**

(a) The permittee shall keep records of the work practice implementation plan and all records associated with fulfilling the requirements of that plan, including but not limited to:

(1) Records demonstrating that the operator training program, required by 25 Pa. Code Section 129.103(b), is in place.

(2) Records maintained in accordance with the leak inspection and maintenance plan required by 25 Pa. Code Section 129.103(c).

(3) Records associated with the cleaning and washoff solvent accounting system required by 25 Pa. Code Section 129.103(d).

(4) Records showing the VOC content of compounds used for cleaning booth components, except for solvent used to clean conveyors, continuous coaters, and their enclosures or metal filters as required by 25 Pa. Code Section 129.103(h) and (i).

(5) Copies of logs and other documentation developed to demonstrate that the other provisions of the work practice implementation plan are followed.

(b) These records shall be retained for a minimum of five (5) years and shall be made available to the Department upon request.

**V. REPORTING REQUIREMENTS.****# 019 [25 Pa. Code §127.441]****Operating permit terms and conditions.**

[Additional authority for this permit condition is derived from 25 Pa. Code Sections 127.1 and 127.12]

(a) The permittee shall submit reports to the Department on a semi-annual basis that include the monthly records of the following information for Source ID P105:

(1) The name and classification (stain, sealer, topcoat, solvent, etc.) of each VOC-containing material as supplied.

(2) The volume used of each VOC-containing material as supplied.

**SECTION D. Source Level Requirements**

- (3) The VOC content (lbs VOC/lb solids and lb VOC/gal material, minus water) of each VOC-containing material as supplied.
- (4) The VOC content (lbs VOC/lb solids and lb VOC/gal coating, minus water) of each as applied coating.
- (5) The content of each individual hazardous air pollutant (lbs HAP/gal material, minus water) of each HAP-containing material.
- (b) If any material used is mixed on site from multiple components rather than used exactly as received from the vendor, the permittee shall submit reports to the Department on a semi-annual basis that include the records of the following for each separate batch of such material:
- (1) The date the batch was mixed,
  - (2) The identity of each component used,
  - (3) The amount of each component used,
  - (4) The VOC content (lbs VOC/lb solids and lb VOC/gal material, minus water) of each component used,
  - (5) The VOC content (lbs VOC/lb solids and lb VOC/gal material, minus water) of the resultant mixed material.
- (c) The semi-annual reports shall be submitted to the Department by no later than March 1 (for January 1 through December 31 of the previous year) and September 1 (for July 1 of the previous year through June 30 of the current year).

**# 020 [25 Pa. Code §129.106]****Reporting requirements**

- (a) The permittee shall submit semi-annual reports including the information required by 25 Pa. Code Section 129.104(c)(3), (c)(4), and (d), a statement of whether the facility was in compliance or noncompliance and, if the facility was in noncompliance, the measures taken to bring the facility into compliance.
- (b) The semi-annual reports shall be submitted to the Department no later than March 1 (for January 1 through December 31 of the previous year) and September 1 (for July 1 of the previous year through June 30 of the current year).
- (c) The permittee shall comply with all applicable reporting requirements as specified in 25 Pa. Code Section 129.106.

**VI. WORK PRACTICE REQUIREMENTS.****# 021 [25 Pa. Code §127.441]****Operating permit terms and conditions.**

[Additional authority for this permit condition is derived from 25 Pa. Code Sections 127.1 and 127.12]

{Compliance with the requirement specified in this streamlined permit condition assures compliance with the provisions in 25 Pa. Code Sections 129.103(f), 129.103(h), and 129.103(i)}

All VOC-containing materials (finishing materials, cleaning solvent, etc.) shall be stored in closed containers when not in actual use; spray gun lines shall be cleaned by flushing solvent through the lines into closed containers; all used cleaning rags shall be stored in closed containers and shall never be "treated" so as to unnecessarily promote the evaporative loss of solvent to atmosphere.

**# 022 [25 Pa. Code §127.441]****Operating permit terms and conditions.**

[Additional authority for this permit condition is derived from 25 Pa. Code Sections 127.1 and 127.12]

- (a) The regenerative thermal oxidizer (ID C105) associated with Source ID P105 shall subject all air-contaminant emissions directed to it to a minimum actual instantaneous temperature of 1,560 degrees Fahrenheit and shall subject these air contaminant emissions to this minimum temperature for at least 0.75 second.

**SECTION D. Source Level Requirements**

(b) The temperature set point for ID C105 shall be at least 1,600 degrees Fahrenheit.

**# 023 [25 Pa. Code §127.441]****Operating permit terms and conditions.**

[Additional authority for this permit condition is derived from 25 Pa. Code Sections 127.1 and 127.12]

At no time shall Source ID P105 be operated unless the oxidizer (ID C105) is simultaneously operating in compliance with all applicable requirements. All VOC emissions from Source ID P105 shall be vented through ID C105.

**# 024 [25 Pa. Code §127.441]****Operating permit terms and conditions.**

[Additional authority for this permit condition is derived from 25 Pa. Code Sections 127.1 and 127.12]

(a) Should the company ever decide to incorporate into Source ID P105 the use of finishing materials other than topcoats, sealers, or stains, the company must obtain written Department approval for the use of these materials prior to their actual use.

(b) Should the company ever decide to incorporate into the glazing line of Source ID P105 the use of finishing materials other than glazing stains, the company must obtain written Department approval for the use of these materials prior to their actual use.

**# 025 [25 Pa. Code §127.441]****Operating permit terms and conditions.**

[Additional authority for this permit condition is derived from 25 Pa. Code Sections 127.1 and 127.12]

{Compliance with the requirement specified in this streamlined permit condition assures compliance with the provisions in 25 Pa. Code Sections 129.52(f) and 129.103(g)}

The permittee shall not cause or permit the emission into the outdoor atmosphere of VOCs from the application of wood furniture coatings unless the coatings are applied using airless, air-assisted airless, curtain coating, roller coating, hand roller, hand brush, flow coating, dip coating, high volume-low pressure application equipment, or an application technique having an equivalent transfer efficiency (as determined solely by the Department).

**# 026 [25 Pa. Code §129.103]****Work practice standards**

[Compliance with the requirement specified in part (b) of this streamlined permit condition assures compliance with the requirement, established pursuant to Best Available Technology (BAT) provisions of 25 Pa. Code Sections 127.1 and 127.12, for the establishment and maintenance of the operator training program]

{Compliance with the requirement specified in part (c) of this streamlined permit condition assures compliance with the requirement, established pursuant to Best Available Technology (BAT) provisions of 25 Pa. Code Sections 127.1 and 127.12, for the establishment and maintenance of the leak detection and repair program}

(a) As specified in 25 Pa. Code Section 129.101(b) (relating to general provisions and applicability), the permittee shall:

(1) Maintain a written work practice implementation plan that defines work practices for each wood furniture manufacturing operation and addresses the provisions in 25 Pa. Code Sections 129.103(b) through 129.103(j). The owner or operator of the facility shall comply with the work practice implementation plan.

(2) Make available the written work practice implementation plan for inspection by the Department upon request. If the Department determines that the work practice implementation plan does not adequately address the criteria specified in 25 Pa. Code Sections 129.103(b) through 129.103(j), the Department may require that the facility owner or operator modify the plan.

**SECTION D. Source Level Requirements**

(b) New and existing personnel, including contract personnel, who are involved in coating, cleaning or washoff operations or implementation of the requirements of 25 Pa. Code Sections 129.101--129.107 shall complete an operator training program.

(1) New personnel shall be trained upon hiring.

(2) Personnel shall be given refresher training annually.

(3) A copy of the written operator training program shall be maintained with the work practice implementation plan. The operator training program shall include the following:

(i) A list of all current personnel by name and job description that are required to be trained.

(ii) An outline of the subjects to be covered in the initial and annual refresher training sessions for each position or group of personnel.

(iii) Lesson plans for courses to be given at the initial and annual refresher training sessions that include, at a minimum, appropriate application techniques, appropriate cleaning and washoff procedures, appropriate equipment setup and adjustment to minimize coating usage and overspray, and appropriate management of cleanup wastes.

(iv) A description of the methods to be used at the completion of the initial or annual refresher training sessions to demonstrate and document successful completion.

(v) A record of the date each employee is trained.

(c) An owner or operator of a facility shall prepare and maintain with the work practice implementation plan a written leak inspection and maintenance plan which shall include the following:

(1) A minimum visual inspection frequency of once per month for all equipment used to transfer or apply coatings or solvents.

(2) An inspection schedule.

(3) The methods for documenting the date and results of each inspection and any repairs that were made.

(4) The time frame between identifying a leak and making the repair, which shall adhere to the following schedule:

(i) A first attempt at repairs, including tightening of packing glands, shall be made within 5 working days after the leak is detected.

(ii) Final repairs shall be made within 15 working days, unless the leaking equipment is to be replaced by a new purchase, in which case repairs shall be completed within 3 months.

(d) A solvent accounting form shall be developed to account for solvents used in cleaning and washoff operations. The information recorded on the form shall include the following:

(1) The total number of pieces processed through washoff operations each month and the reason for the washoff operations.

(2) The name and total quantity of each solvent used each month for:

(i) Cleaning activities.

(ii) Washoff operations.

(3) The name and total quantity of each solvent evaporated to the atmosphere each month from:

**SECTION D. Source Level Requirements**

- (i) Cleaning activities.
- (ii) Washoff operations.
- (e) An owner or operator of a facility may not use compounds containing more than 8.0% by weight of VOC for cleaning spray booth components other than conveyors, continuous coaters and their enclosures, or metal filters, unless the spray booth is being refurbished. If the spray booth is being refurbished, that is, the spray booth coating or other material used to cover the booth is being replaced, the facility shall use no more than 1.0 gallon of solvent to prepare the booth prior to applying the booth coating.
- (f) An owner or operator of a facility may not use conventional air spray guns to apply coatings.
- (g) The emissions from washoff operations shall be controlled by the following:
  - (1) Using normally closed containers for washoff operations.
  - (2) Minimizing dripping by tilting or rotating the part to drain as much solvent as possible.

**VII. ADDITIONAL REQUIREMENTS.****# 027 [25 Pa. Code §127.441]****Operating permit terms and conditions.**

(a) Source ID P105 is a finishing operation, which consists of the following:

- (1) Two (2) stain automated paint booths, self contained units, has one (1) flash off/curing oven each that are heated by steam from Source IDs 031 and 032,
- (2) Two (2) topcoat automated paint booths, self contained units, has one (1) flash off/curing oven each that are heated by steam from Source IDs 031 and 032,
- (3) Two (2) sealer automated paint booths, self contained units, has one (1) flash off/curing oven each that are heated by steam from Source IDs 031 and 032,
- (4) Two (2) glazing manual paint booths, located in series on glazing line,
- (5) One (1) glazing flash off/curing oven that is heated by steam from Source IDs 031 and 032,
- (6) One (1) special projects manual paint booth,
- (7) Hand wiping operations,
- (8) Cleaning operations.

(b) ID C105 is a Durr model 125K-16.5x12-800 regenerative thermal oxidizer, rated at 13.4 million Btu per hour, natural gas fired, located in the finishing area.

**# 028 [25 Pa. Code §127.441]****Operating permit terms and conditions.**

Source ID P105 is subject to 25 Pa. Code Sections 129.52 and 129.101 through 129.107. The permittee shall comply with all applicable requirements specified in 25 Pa. Code Sections 129.52 and 129.101 through 129.107.

**# 029 [25 Pa. Code §127.441]****Operating permit terms and conditions.**

- (a) Source ID P105 and control device C105 were deactivated on October 30, 2019.
- (b) The permittee submitted a maintenance plan dated June 3, 2020 in accordance with 25 Pa. Code Sections 127.11a(a)(1) and (3). This plan was approved by the Department via letter dated July 21, 2020.



**SECTION D. Source Level Requirements**

- (c) In accordance with 25 Pa. Code Section 127.11a(a)(2), should the permittee reactivate Source ID P105 and control device C105 by no later than October 30, 2024, the permittee shall submit a reactivation plan at least 60 days prior to the proposed date of reactivation. The reactivation plan shall include sufficient measures to ensure that Source ID P105 and control device C105 will be reactivated in compliance with the conditions of this operating permit. The permittee may submit a reactivation plan to the Department at any time during the term of this operating permit. The reactivation plan may also be submitted to and reviewed by the Department as part of a plan approval or permit application, or the renewal process.
- (d) Should the reactivation of Source ID P105 and control device C105 occur after October 30, 2024, the permittee shall follow the requirements of 25 Pa. Code Section 127.11a(b).
- (e) Should the reactivation of Source ID P105 and control device C105 occur after October 30, 2029, the permittee shall follow the requirements of 25 Pa. Code Section 127.11a(c).

**SECTION D. Source Level Requirements**

Source ID: P106

Source Name: PREDRYER

Source Capacity/Throughput:

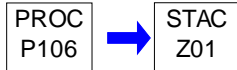
**I. RESTRICTIONS.**

No additional requirements exist except as provided in other sections of this permit including Section B (State Only General Requirements).

**II. TESTING REQUIREMENTS.**

No additional testing requirements exist except as provided in other sections of this permit including Section B (State Only General Requirements).

**III. MONITORING REQUIREMENTS.**

No additional monitoring requirements exist except as provided in other sections of this permit including Section B (State Only General Requirements).

**IV. RECORDKEEPING REQUIREMENTS.****# 001 [25 Pa. Code §127.441]****Operating permit terms and conditions.**

(a) The permittee shall keep records, on a monthly basis, of the total amount of lumber in board feet processed in Source ID P106.

(b) These records shall be retained for a minimum of five (5) years and shall be made available to the Department upon request.

**V. REPORTING REQUIREMENTS.****# 002 [25 Pa. Code §127.441]****Operating permit terms and conditions.**

(a) The permittee shall submit reports to the Department on a semi-annual basis that include the records of the total amount of lumber in board feet processed in Source ID P106.

(b) The semi-annual reports shall be submitted to the Department by no later than March 1 (for January 1 through December 31 of the previous year) and September 1 (for July 1 of the previous year through June 30 of the current year).

**VI. WORK PRACTICE REQUIREMENTS.**

No additional work practice requirements exist except as provided in other sections of this permit including Section B (State Only General Requirements).

**VII. ADDITIONAL REQUIREMENTS.****# 003 [25 Pa. Code §127.441]****Operating permit terms and conditions.**

Source ID P106 is an SII Kilns model Excell predryer, capable of being heated by steam from Source IDs 031 and 032, rated at 13.44 million board feet per year, occupies one building by itself.

**SECTION D. Source Level Requirements**

Source ID: P107

Source Name: STORAGE TANKS

Source Capacity/Throughput:

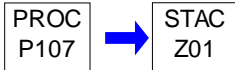
**I. RESTRICTIONS.****Emission Restriction(s).**

# 001 [25 Pa. Code §127.441]

**Operating permit terms and conditions.**

- (a) The combined volatile organic compound (VOC) emissions from Source ID P107 shall be less than 2.7 tons per 12 consecutive month period.
- (b) The combined hazardous air pollutant (HAP) emissions from Source ID P107 shall be less than 1.0 tons per 12 consecutive month period.

**II. TESTING REQUIREMENTS.**

No additional testing requirements exist except as provided in other sections of this permit including Section B (State Only General Requirements).

**III. MONITORING REQUIREMENTS.**

No additional monitoring requirements exist except as provided in other sections of this permit including Section B (State Only General Requirements).

**IV. RECORDKEEPING REQUIREMENTS.**

# 002 [25 Pa. Code §127.441]

**Operating permit terms and conditions.**

The permittee shall maintain comprehensive, accurate records that provide the information necessary to calculate the VOC and HAP emission rates from Source ID P107 on a monthly basis. These records shall be maintained for at least five years and made available to the Department upon request.

**V. REPORTING REQUIREMENTS.**

No additional reporting requirements exist except as provided in other sections of this permit including Section B (State Only General Requirements).

**VI. WORK PRACTICE REQUIREMENTS.**

# 003 [25 Pa. Code §129.57]

**Storage tanks less than or equal to 40,000 gallons capacity containing VOCs**

The permittee shall not store any liquid containing volatile organic compounds (VOCs) with a vapor pressure greater than 1.5 psia (10.5 kilopascals) under actual storage conditions in Source ID P107 unless the tank(s) is/are equipped with pressure relief valves which are maintained in good operating condition and which are set to release at no less than 0.7 psig of pressure or 0.3 psig of vacuum, or the highest possible pressure and vacuum in accordance with state or local fire codes or the National Fire Prevention Association guidelines or other national consensus standards acceptable to the Department.

**VII. ADDITIONAL REQUIREMENTS.**

# 004 [25 Pa. Code §127.441]

**Operating permit terms and conditions.**

**SECTION D. Source Level Requirements**

Source ID P107 consists of two 7,200 gallon storage tanks.

**SECTION D. Source Level Requirements**

Source ID: P108

Source Name: PRESSROOM PRESSES

Source Capacity/Throughput:

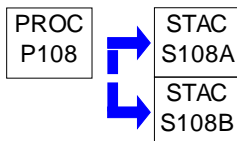
**I. RESTRICTIONS.****Emission Restriction(s).****# 001 [25 Pa. Code §127.441]****Operating permit terms and conditions.**

No volatile organic compound-containing or hazardous air pollutant-containing glues or adhesives may be used in Source ID P108 other than glues and adhesives which have only a residual formaldehyde and/or VOC content. The combined emission of formaldehyde and/or VOCs resulting from the use of such glues and adhesives shall not, however, equal or exceed 1.5 tons in any 12 consecutive month period.

The 1.5 ton limit is derived from a 1.0 ton limit established in Plan Approval 08-318-027 pursuant to 25 Pa. Code Sections 127.1 and 127.12 and an additional 0.5 ton limit approved via an August 9, 2017 RFD.

**II. TESTING REQUIREMENTS.**

No additional testing requirements exist except as provided in other sections of this permit including Section B (State Only General Requirements).

**III. MONITORING REQUIREMENTS.**

No additional monitoring requirements exist except as provided in other sections of this permit including Section B (State Only General Requirements).

**IV. RECORDKEEPING REQUIREMENTS.**

No additional record keeping requirements exist except as provided in other sections of this permit including Section B (State Only General Requirements).

**V. REPORTING REQUIREMENTS.**

No additional reporting requirements exist except as provided in other sections of this permit including Section B (State Only General Requirements).

**VI. WORK PRACTICE REQUIREMENTS.**

No additional work practice requirements exist except as provided in other sections of this permit including Section B (State Only General Requirements).

**VII. ADDITIONAL REQUIREMENTS.****# 002 [25 Pa. Code §127.441]****Operating permit terms and conditions.**

Source ID P108 consists of the pressroom presses that are used to apply veneer to wood and wood products, has two (2) stacks that are rated at 15,000 ACFM total.

**SECTION D. Source Level Requirements**

The Wemhoner veneer press was constructed pursuant to an April 29, 2014 RFD.

**SECTION D. Source Level Requirements**

Source ID: P109

Source Name: INTERNAL COMBUSTION SOURCES

Source Capacity/Throughput:

N/A

Diesel Fuel

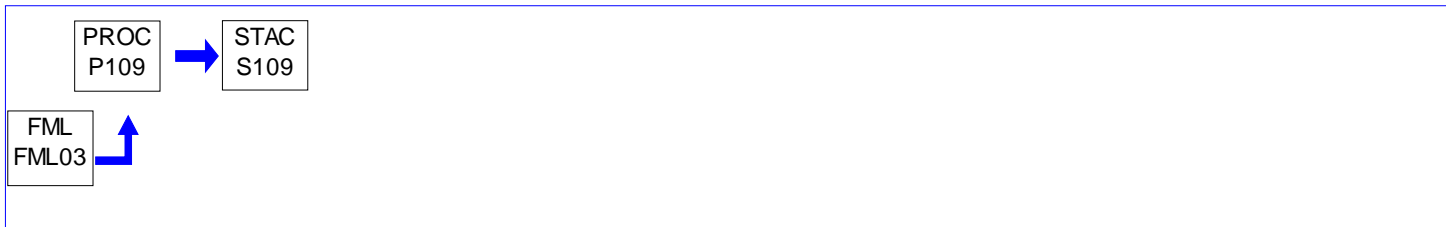
**I. RESTRICTIONS.****Emission Restriction(s).****# 001 [25 Pa. Code §123.13]****Processes**

No person may permit the emission of particulate matter from the exhaust of each internal combustion unit of Source ID P109 into the outdoor atmosphere in a manner that the concentration in the effluent gas exceeds 0.04 grain per dry standard cubic foot.

**# 002 [25 Pa. Code §123.21]****General**

No person may permit the emission into the outdoor atmosphere of sulfur oxides, expressed as SO<sub>2</sub>, from the exhaust of each internal combustion unit of Source ID P109 in a manner that the concentration of the sulfur oxides in the effluent gas exceeds 500 parts per million, by volume, dry basis.

**# 003 [25 Pa. Code §127.441]****Operating permit terms and conditions.**

[Additional authority for this permit condition is derived from the permittee requesting the plan approval exemption limitations]

The total combined emission of nitrogen oxides (NO<sub>x</sub>), expressed as NO<sub>2</sub>, from all internal combustion units of Source ID P109 shall not equal or exceed 100 pounds per hour, 1,000 pounds per day, 2.75 tons per ozone season, and 6.6 tons in any 12 consecutive month period.

**Operation Hours Restriction(s).****# 004 [40 CFR Part 63 NESHAPS for Source Categories §40 CFR 63.6640]****Subpart ZZZZ - National Emissions Standards for Hazardous Air Pollutants for Stationary Reciprocating Internal Combustion Engines****How do I demonstrate continuous compliance with the emission limitations, operating limitations, and other requirements?**

The emergency generators incorporated in Source P109 may be operated for the purpose of maintenance checks and readiness testing, provided that the tests are recommended by Federal, State or local government, the manufacturer, the vendor, or the insurance company associated with the emergency generator. Maintenance checks and readiness testing of such units is limited to 100 hours per year. The permittee may petition the Department for approval of additional hours to be used for maintenance checks and readiness testing, but a petition is not required if the permittee maintains records indicating that Federal, State, or local standards require maintenance and testing of any emergency generator incorporated in Source P109 beyond 100 hours per year. The emergency generators incorporated in Source P109 may operate up to 50 hours per year in non-emergency situations, but those 50 hours are counted towards the 100 hours per year provided for maintenance and testing. The 50 hours per year for non-emergency situations cannot be used for peak shaving or to generate income for a facility to supply power to an electric grid or otherwise supply power as part of a financial arrangement with another entity. Any operation of any emergency generator incorporated in Source P109, other than emergency operation, maintenance and testing, and operation in non-emergency situations for 50 hours per year, as permitted in this condition, is prohibited.

**SECTION D. Source Level Requirements****II. TESTING REQUIREMENTS.**

No additional testing requirements exist except as provided in other sections of this permit including Section B (State Only General Requirements).

**III. MONITORING REQUIREMENTS.**

No additional monitoring requirements exist except as provided in other sections of this permit including Section B (State Only General Requirements).

**IV. RECORDKEEPING REQUIREMENTS.****# 005 [25 Pa. Code §127.441]****Operating permit terms and conditions.**

(a) The permittee shall keep records of the supporting calculations for NOx emissions from all internal combustion units of Source ID P109 on a monthly basis and shall verify compliance with the NOx emission limitations.

(b) These records shall be retained for a minimum of five (5) years and shall be made available to the Department upon request.

**# 006 [40 CFR Part 63 NESHAPS for Source Categories §40 CFR 63.6655]****Subpart ZZZZ - National Emissions Standards for Hazardous Air Pollutants for Stationary Reciprocating Internal Combustion Engines****What records must I keep?**

The permittee shall keep records pertaining to Source ID P109 as specified in 40 CFR 63.6655 and 40 CFR 63.6660.

**V. REPORTING REQUIREMENTS.****# 007 [25 Pa. Code §127.441]****Operating permit terms and conditions.**

(a) The permittee shall submit reports to the Department on a semi-annual basis that include the supporting calculations used to verify compliance with the NOx emission limitations for all internal combustion units of Source ID P109.

(b) The semi-annual reports shall be submitted to the Department no later than March 1 (for January 1 through December 31 of the previous year) and September 1 (for July 1 of the previous year through June 30 of the current year).

**# 008 [25 Pa. Code §127.441]****Operating permit terms and conditions.**

The submission of all requests, reports, application submittals, and other communications required by NESHAPs Subpart ZZZZ must be made to both the U.S. Environmental Protection Agency and the Pennsylvania Department of Environmental Protection. The copies may be sent to:

Office of Air Enforcement and Compliance Assistance (3AP20)  
United States Environmental Protection Agency  
Region 3  
1650 Arch Street  
Philadelphia, PA 19103-2029

and

The Pennsylvania Department of Environmental Protection  
Air Quality Program Manager  
208 W. Third Street, Suite 101  
Williamsport, PA 17701-6448



**SECTION D. Source Level Requirements****VI. WORK PRACTICE REQUIREMENTS.****# 009 [40 CFR Part 63 NESHAPS for Source Categories §40 CFR 63.6603]****Subpart ZZZZ - National Emissions Standards for Hazardous Air Pollutants for Stationary Reciprocating Internal Combustion Engines****What emission limitations, operating limitations, and other requirements must I meet if I own or operate an existing stationary RICE located at an area source of HAP emissions?**

Pursuant to 40 CFR 63.6603, the permittee must:

- a) Change oil and filter of Source ID P109 every 500 hours of operation or annually, whichever comes first, unless the oil analysis program detailed in 40 CFR 63.6625(i) indicates the oil does not need to be changed.
- b) Inspect the air cleaner of Source ID P109 every 1,000 hours of operation or annually, whichever comes first.
- c) Inspect all hoses and belts of Source ID P109 every 500 hours of operation or annually, whichever comes first, and replace as necessary.

**# 010 [40 CFR Part 63 NESHAPS for Source Categories §40 CFR 63.6625]****Subpart ZZZZ - National Emissions Standards for Hazardous Air Pollutants for Stationary Reciprocating Internal Combustion Engines****What are my monitoring, installation, operation, and maintenance requirements?**

Pursuant to 40 CFR 63.6625(e), the permittee must operate and maintain Source ID P109 according to the manufacturer's emission-related written instructions or develop their own maintenance plan which must provide to the extent practicable for the maintenance and operation of the engine in a manner consistent with good air pollution control practice for minimizing emissions.

**VII. ADDITIONAL REQUIREMENTS.****# 011 [25 Pa. Code §127.441]****Operating permit terms and conditions.**

Source ID P109 consists of internal combustion units that include the following:

- (a) A Curtis Manufacturing model GOIC emergency generator, 400 kW unit, engine rated at 535 horsepower, located in the boiler room and used to power boilers in emergency situations,
- (b) A Clarke Detroit Diesel - Allison, Inc. model VMPP-T6HT 3433H fire sprinkler system pump, engine rated at 146 horsepower, located in the pumphouse.

**# 012 [40 CFR Part 63 NESHAPS for Source Categories §40 CFR 63.6585]****Subpart ZZZZ - National Emissions Standards for Hazardous Air Pollutants for Stationary Reciprocating Internal Combustion Engines****Am I subject to this subpart?**

Source ID P109 is subject to 40 CFR Part 63 Subpart ZZZZ - National Emissions Standards for Hazardous Air Pollutants for Stationary Reciprocating Internal Combustion Engines. The permittee shall comply with all the applicable requirements specified in 40 CFR Sections 63.6580 through 63.6675.



**SECTION E. Source Group Restrictions.**



**SECTION F. Alternative Operation Requirements.**

No Alternative Operations exist for this State Only facility.



**SECTION G. Emission Restriction Summary.**

No emission restrictions listed in this section of the permit.

**SECTION H. Miscellaneous.**

The following air contaminant sources are considered to the Department to be insignificant with regards to air contaminant emissions and are determined to be exempt from permitting requirements. However, this determination does not exempt the sources from compliance with all applicable State and Federal regulations, including all applicable regulations specified in 25 Pa. Code Chapters 121-145:

- (a) One (1) polyvinyl acetate (PVA) glue spray operation located in the door manufacturing area (approved via RFD on June 9, 2016),
- (b) Finishing room dust control, four (4) units that vent indoors, located outside finishing area,
- (c) Maintenance shop baghouse, vents indoors, located inside maintenance shop,
- (d) One (1) propane storage tank, 1000 gallon capacity, located outside mixing area,
- (e) One (1) diesel storage tank, 500 gallon capacity, located outside mixing area,
- (f) Two (2) oil-water separators, underground, located outside main plant,
- (g) One (1) hot water heater, A.O. Smith, model BTR 200 104, rated at 0.199 MMBtu/hr, natural gas fired, 100 gallon capacity, located outside the cafeteria kitchen,
- (h) Two (2) Safety-Kleen parts washers, solvent used contains less than 5% VOCs and no HAPs.



\*\*\*\*\* End of Report \*\*\*\*\*

---